

Assembly instructions

Paxa Furniture group

List of contents

Product Overview	s. 2
Fastening Ground fixed	s. 3
Fastening Ground fixed with undercasting	s. 4
Seat and Frame	s. 5
Backrest	s. 6
Armrest	s. 7
Dimensions of Paxa Table	s. 8
Dimensions of Paxa 1 Bench	s. 9
Dimensions of Paxa 2 Bench	s. 10
Dimensions of Paxa 3 Bench	s. 11

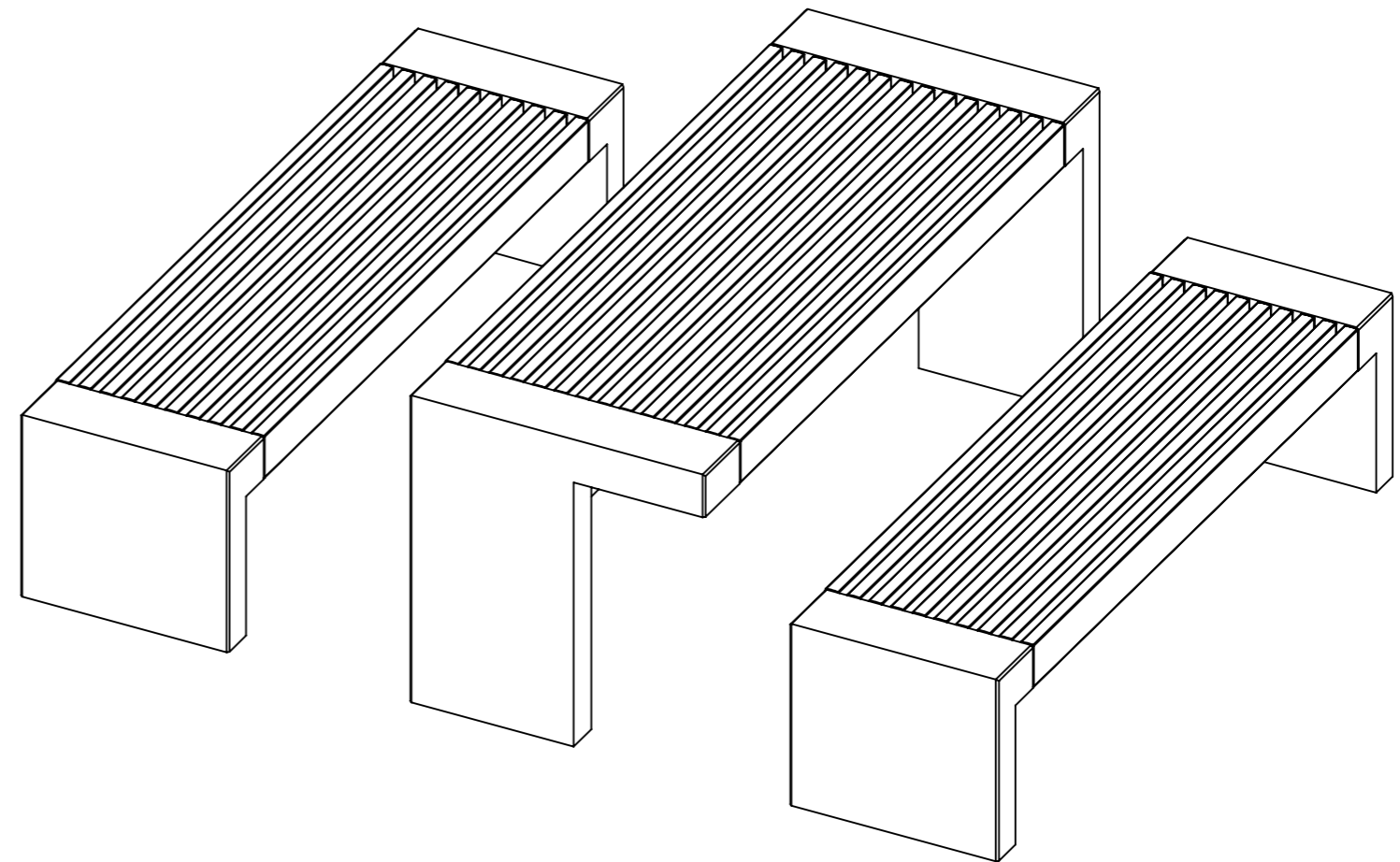

Paxa Furniture group

Product overview

Ritad av Joachim Henriksson
Ritad datum 2024-03-27

U20-59 Paxa Table

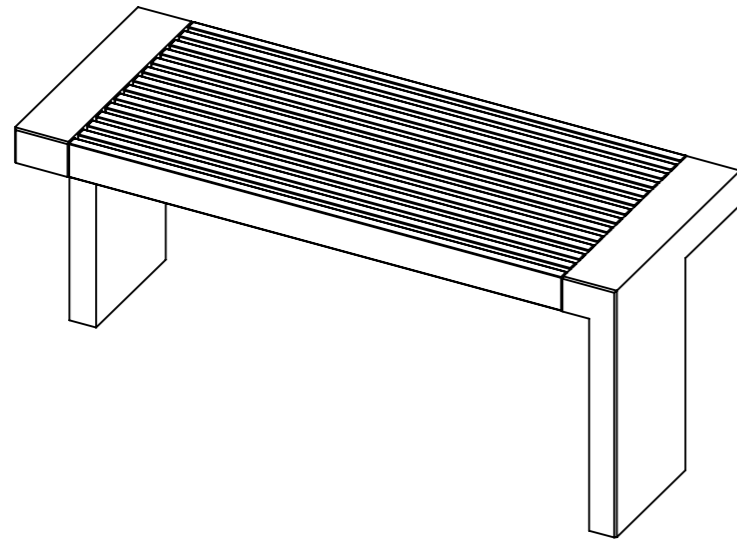

U20-60 Paxa 1 Bench

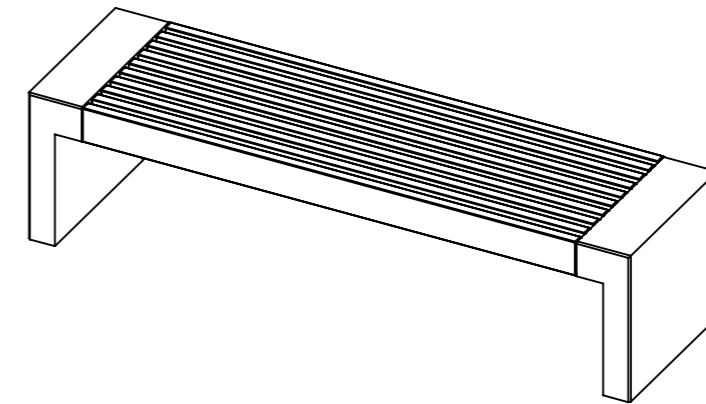

U20-64 Paxa 2 Bench

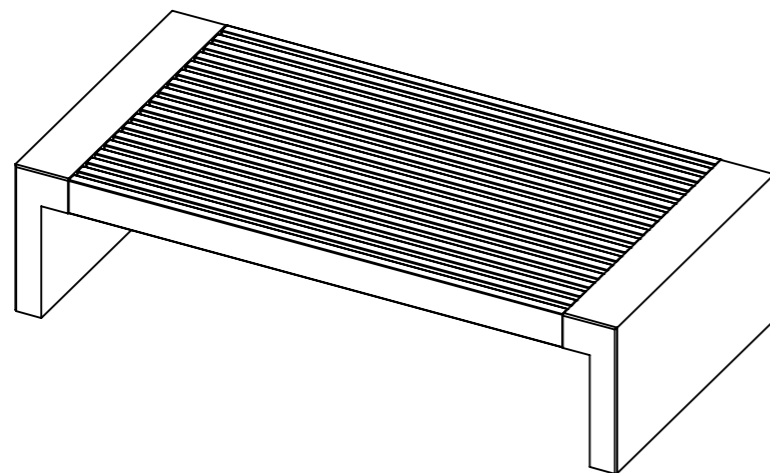

U20-68 Paxa 3 Bench

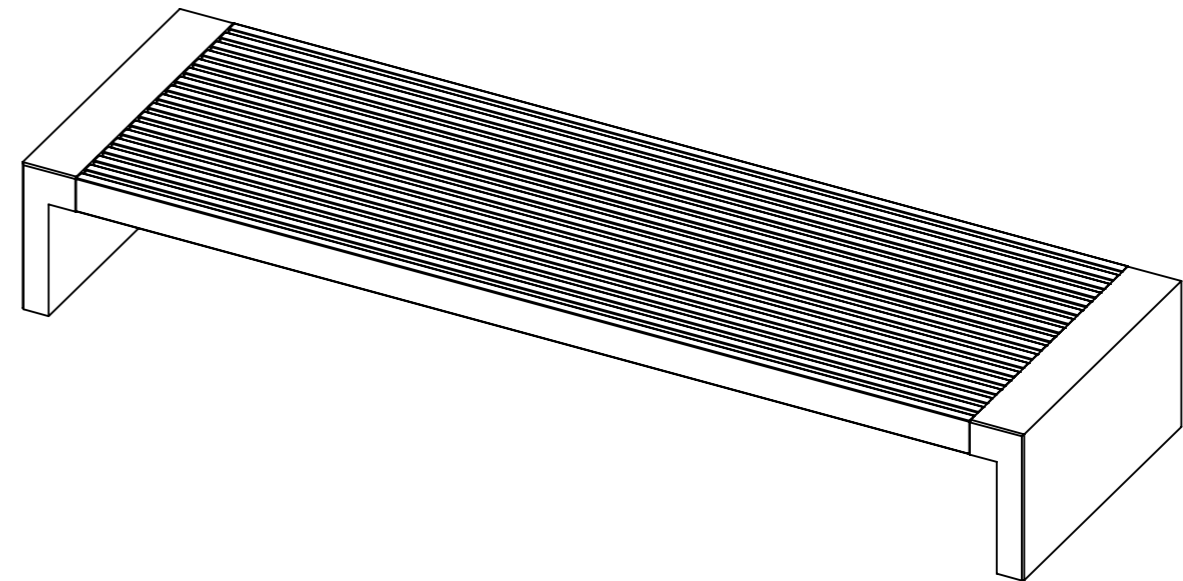

Paxa Furniture Fastening Ground Fixed

Ritad av Joachim Henriksson
Ritad datum 2023-12-15

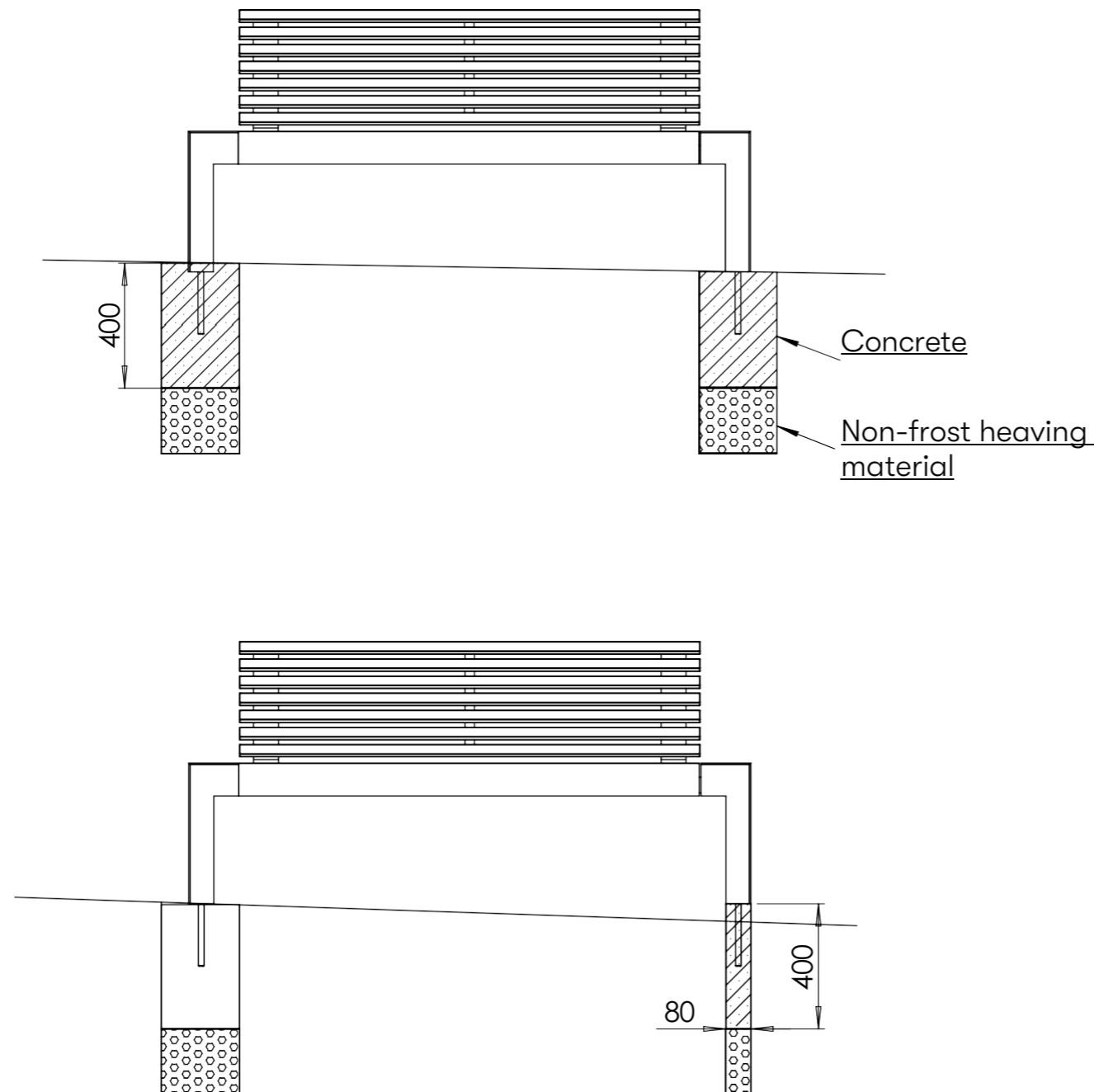

Attachment

Fastening Ground Fixed

If the ground slopes, the ground slope must be taken up in the stands. This means that one of the stands will be at a lower height than normal seat height. See the first picture.

1. Install the threaded rods in the underside of the concrete frame.
2. Excavate the ground to a frost-free depth.
3. Fill up with non-frost heaving material to a height of 400 mm below the finished ground.
4. Fill in concrete, brace and set up the concrete frames.

It is also possible to mount one frame at normal seat height while the other frame is undercast so that it has the right seat height. See the second picture.

This means that you cast underneath that stand and cast a plinth with dimensions similar to the stand. 500 x 80 mm (Paxa 1), 900 x 80 mm (Paxa 2 and 3).

After the plinth has been cast, the plinth for kerb angle bolts C-C 300 (Paxa 1), C-C 700 (Paxa 2 and 3) is drilled. The holes are filled with expanding concrete and the plinth with input bolts is placed in place.

Paxa Furniture Fastening Ground Fixed

Ritad av Joachim Henriksson
Ritad datum 2023-12-15

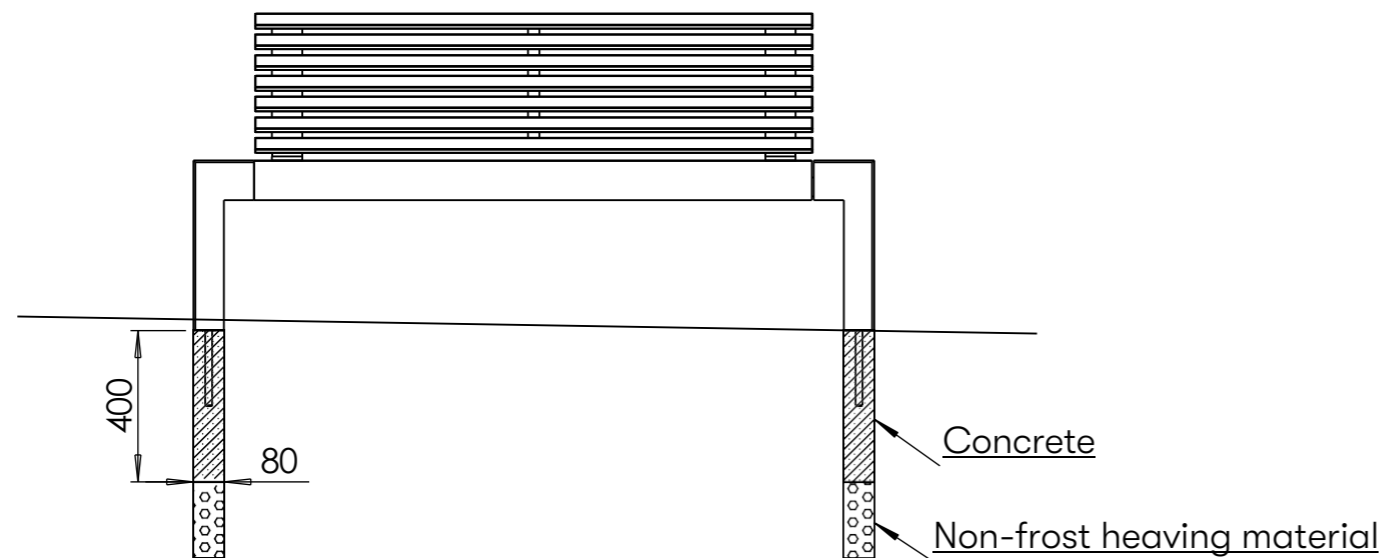

Attachment

If the bench is to be set up on soft ground, grass, gravel or similar, the stands must be undercast.

Installation Ground fixed with undercasting

1. Excavate the ground to a frost-free depth.
2. Fill up with non-frost heaving material to a height of 400 mm below the finished ground.
3. Cast a plinth for each stand with the dimensions 80 x 500 mm (Paxa 1), 80 x 900 mm (Paxa 2 and 3) and 400 mm deep and with recesses for the plinth studs. The studs are located 100 mm from the outer edges.
4. Install the bench seat to the stands with the bolts attached.
5. When the cast-in-place frames have burned, the bench frames are placed on the foundations with kerb angle bolts. They are cemented with expanding concrete.

Paxa Furniture

Mounting Seat and Stand

Ritad av Joachim Henriksson
Ritad datum 2023-12-15

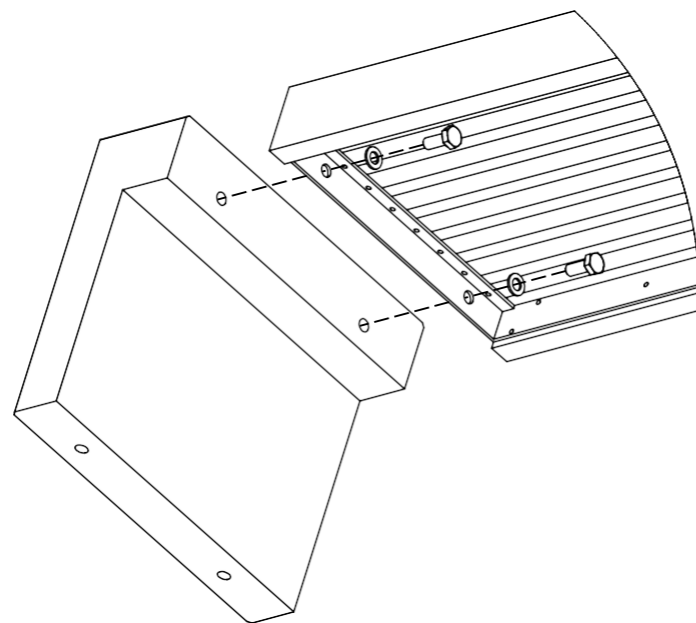
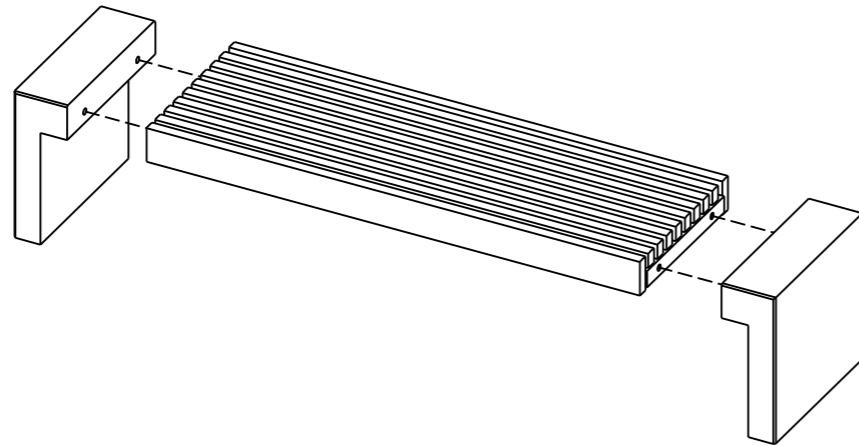

Mounting Seat and Stand

The bench frames are set up on a horizontal surface. They can be set up free-standing but can also be cast into the ground with the included studs.

Then attach the seat to the concrete frames with the included M16 x 40 mm bolt and washer. As illustrated in the pictures. The concrete frames are fitted with threaded holes so no nut is required.

Make sure the seat and edge of the stand live.

Paxa Furniture

Mounting backrest

Ritad av Joachim Henriksson
Ritad datum 2023-12-15

U20-67R

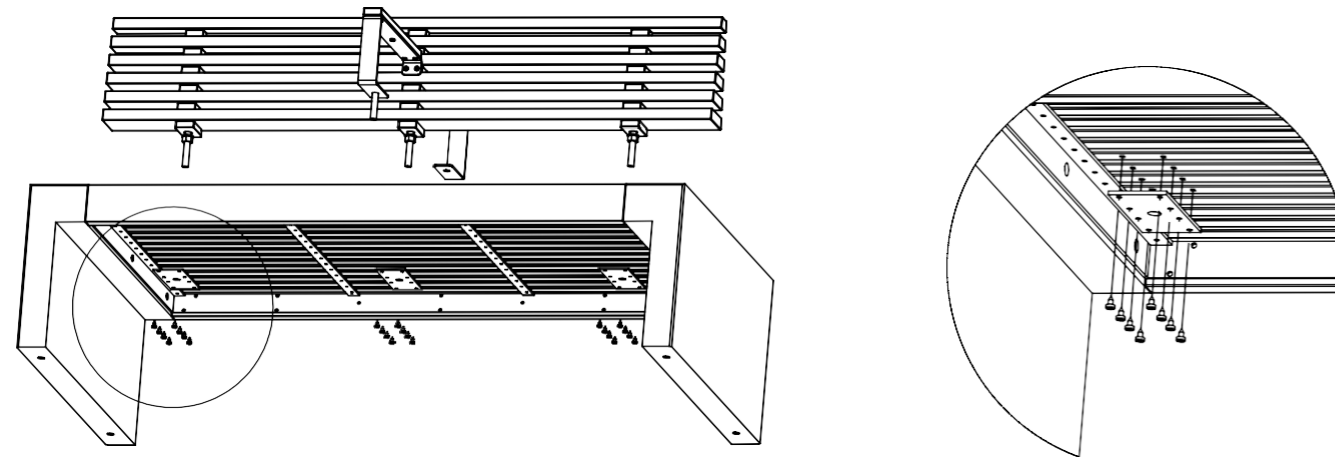

The backrest **U20-60R** for Paxa 1, seat is delivered assembled. It is important that the order is placed together.

The U20-67R **backrest** for Paxa 2, seat is delivered unassembled and mounted with associated washers, nuts and screws. The backrest can be ordered retrospectively. If armrests are desired for **the U20-67R**, this is delivered mounted against the back and both are mounted at the same time as one.

Mounting backrest

1. Place the backrest and measure so it is centered in length and width.
2. Assemble the large washer and secure it with the wood screws.
3. Install the nuts and fasten the backrest so that it is secure.

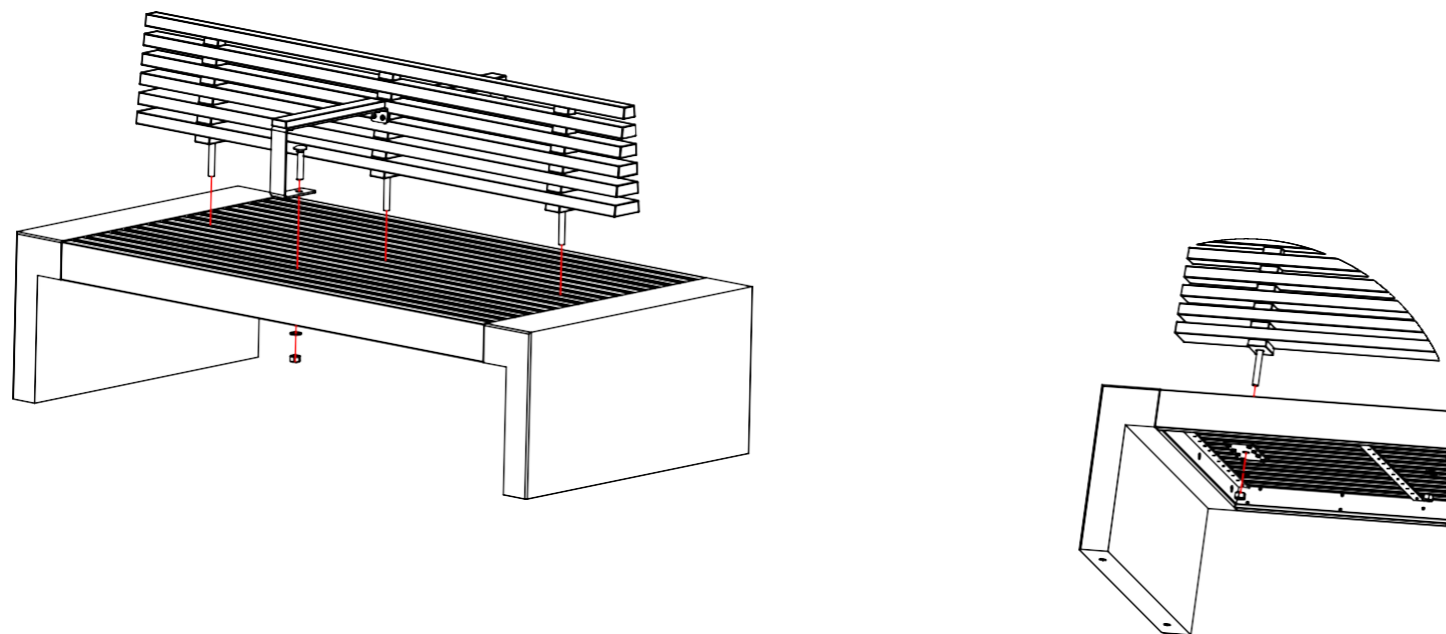

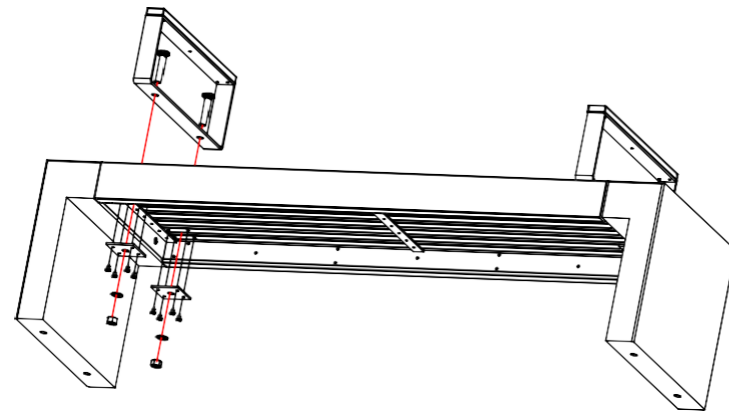

Armrest **U20-60/ARM** for Paxa 1, seat without backrest, delivered unassembled. Supplied incl. fasteners.

Armrest **U20-64/ARM** for Paxa with back. For Paxa 2 and 3 with backrest, the armrest is delivered mounted in combination with the backrest. Supplied with. fasteners.

Mounting Armrests

The armrests are installed according to the same principle as the backrest.

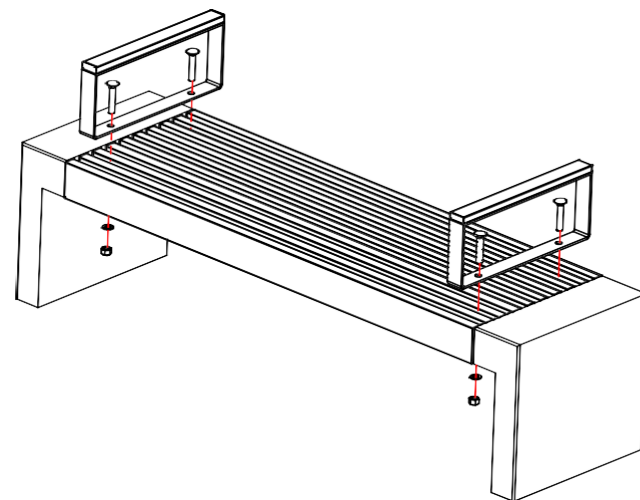

1. Place armrests at the selected location. It is recommended to place an armrest at each end of the seat section, possibly an armrest in the middle for accessibility.
2. Measure so that the armrest is centered in length and width.
3. Install the large tray under the seat and secure it with wood screws to the boards of the seat.
4. Install the nuts and then tighten the armrest so that it sits firmly.

Paxa Furniture group

Dimensions Paxa Table

Ritad av Joachim Henriksson
Ritad datum 2024-03-27

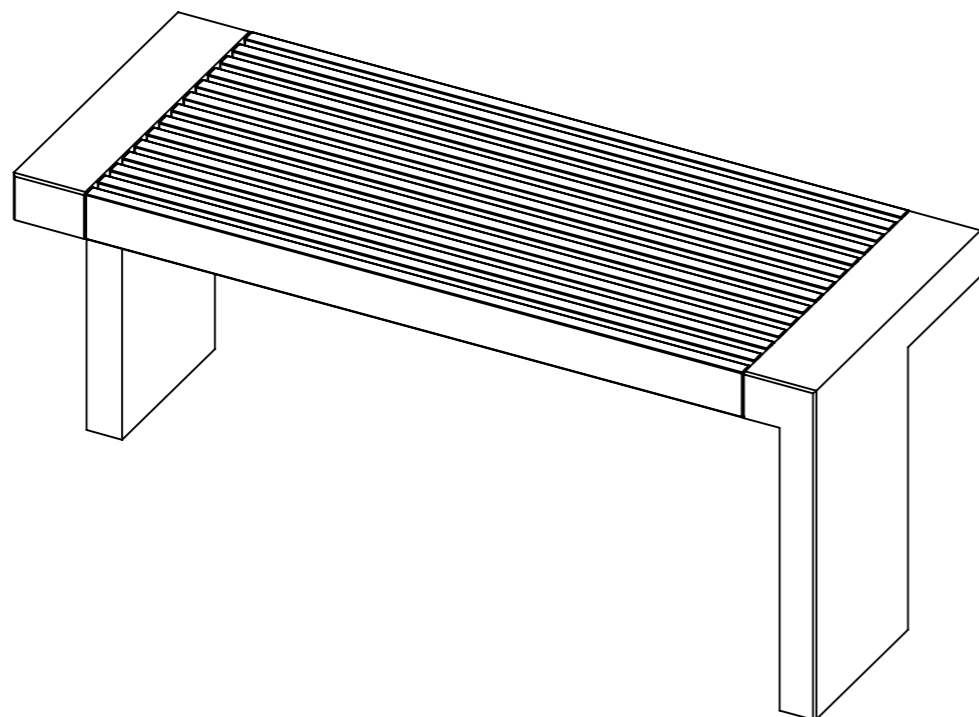

U20-59 Paxa Table
Weight: 230 kg

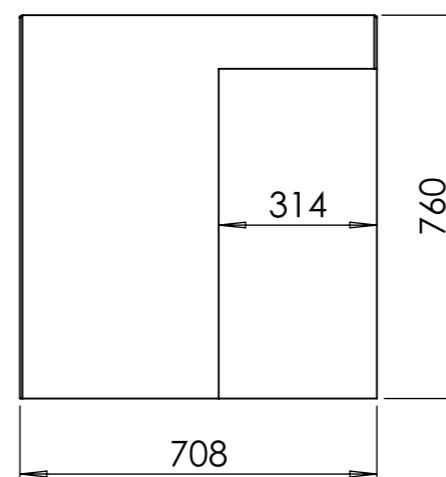
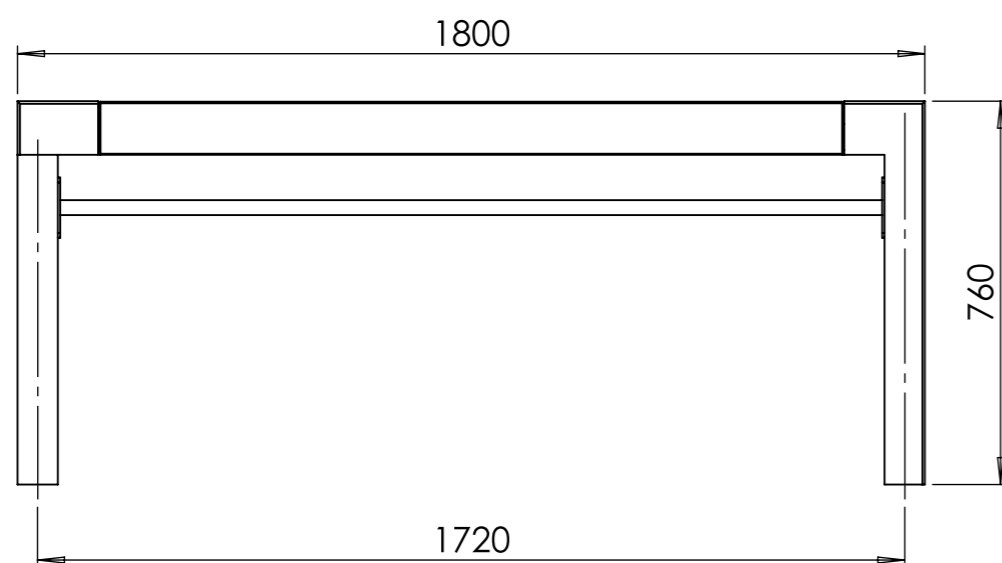

Paxa Furniture group

Dimensions Paxa 1 Bench

Ritad av Joachim Henriksson
Ritad datum 2024-03-27

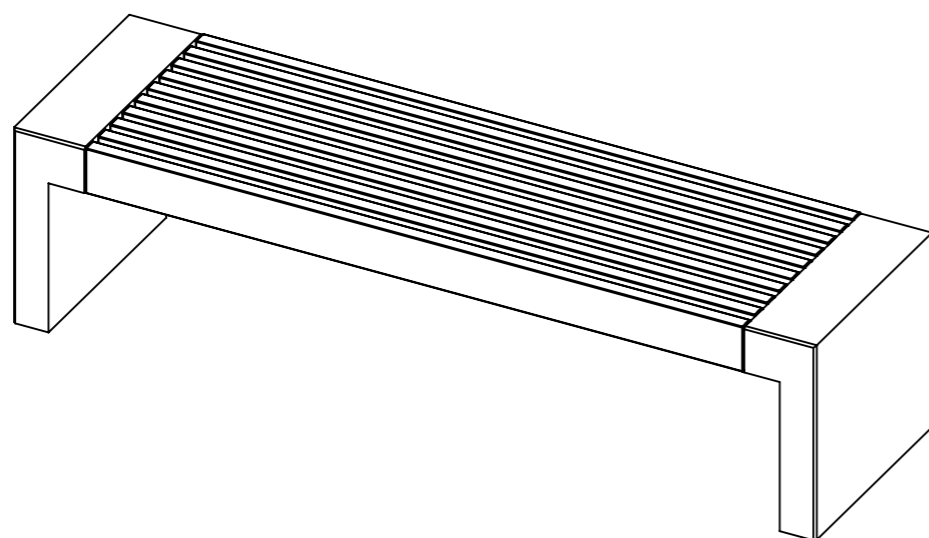

U20-60 Paxa 1 Bench
Weight: 150 kg

Additional:

U20-60/ARM Armrest for Paxa 1 Bench
U20-60R Backrest for Paxa 1 Bench
U20-64/ARM Armrest for Paxa with backrest

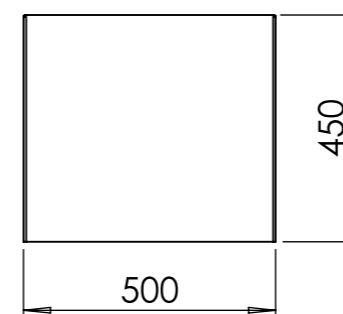
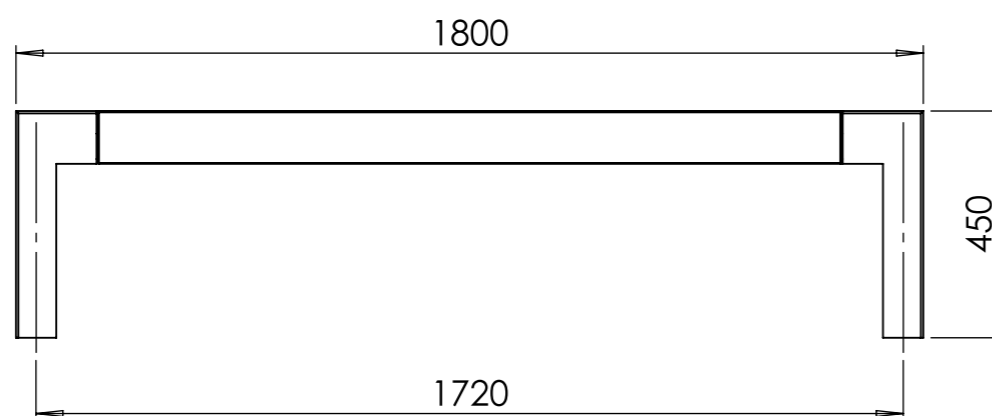

Paxa Furniture group

Dimensions Paxa 2 Bench

Ritad av Joachim Henriksson
Ritad datum 2024-03-27

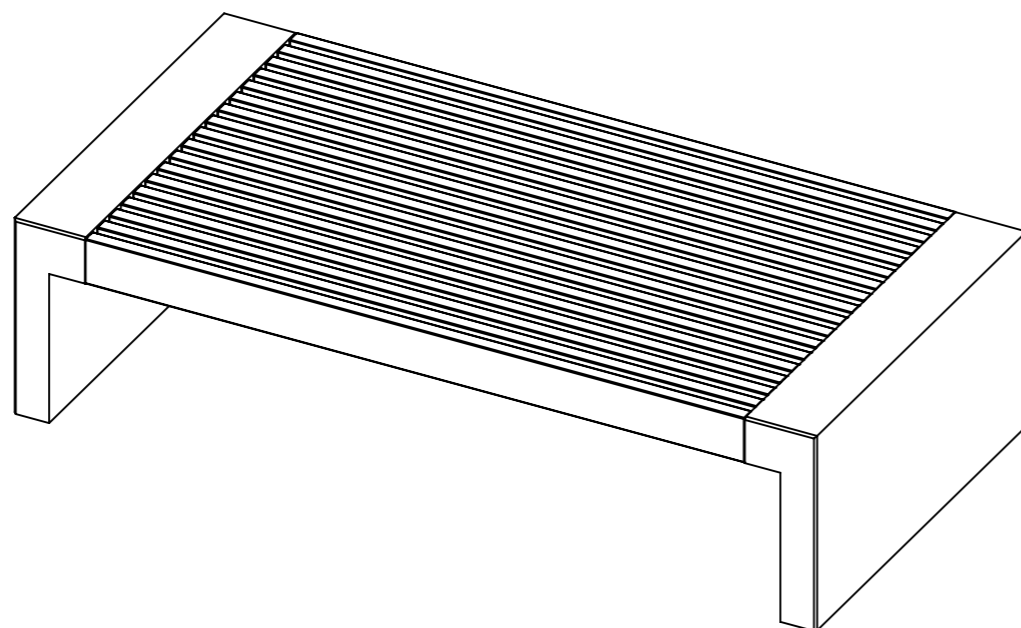

U20-64 Paxa 2 Bench
Weight: 233 kg

Additional:

U20-64R Backrest for Paxa 2 and 3 Bench
U20-64/ARM Armrest for Paxa with backrest

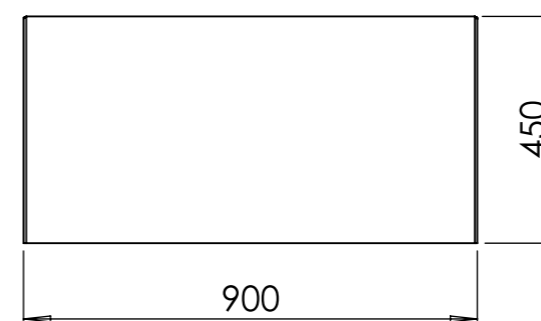
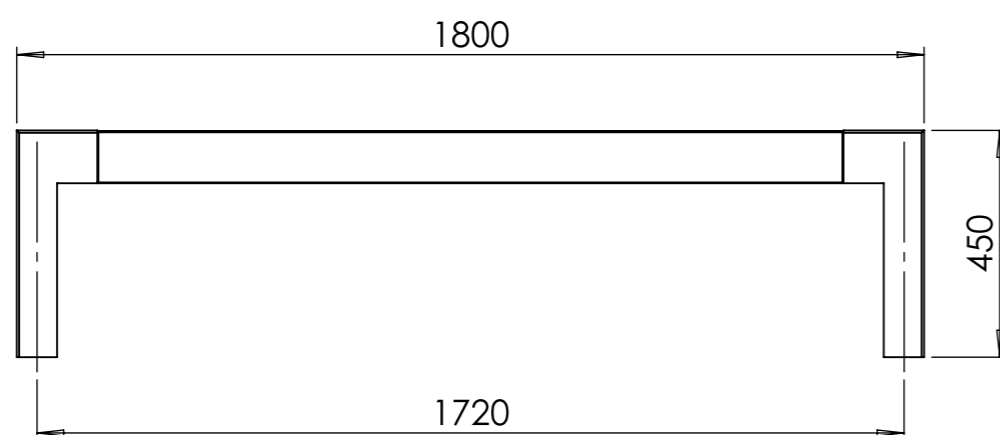

Paxa Furniture group

Dimensions Paxa 3 Bench

Ritad av Joachim Henriksson
Ritad datum 2024-03-27

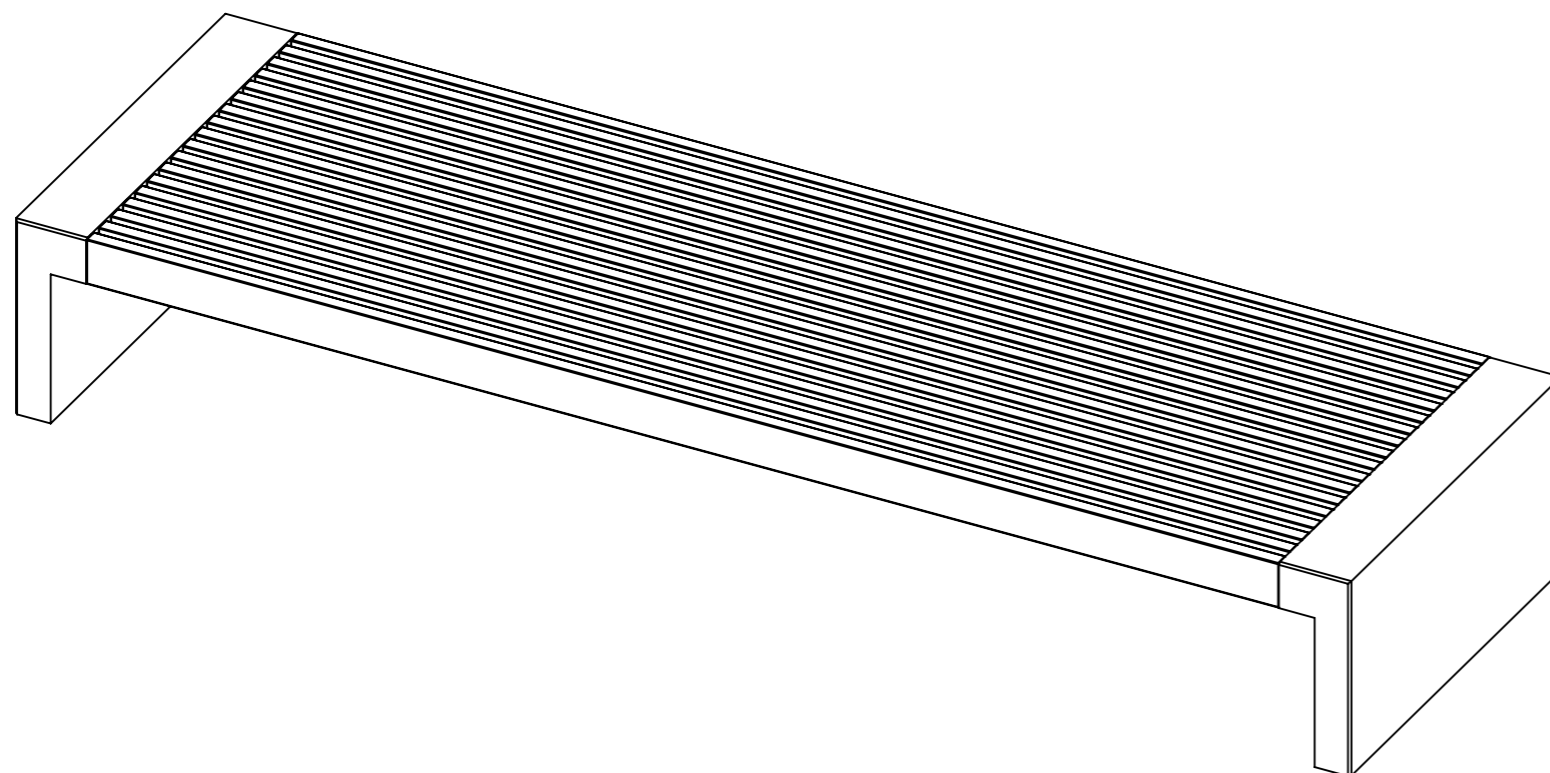

U20-68 Paxa 3 Bench
Weight: 361 kg

Additional:

U20-64R Backrest for Paxa 2 and 3 Bench
U20-64/ARM Armrest for Paxa with backrest

