

Assembly instructions

High Bench möbelsystem

Table of contents

Overview furniture system	s. 2
Assembly order	s. 3
Attaching legs	s. 4
Attaching coupling table	s. 5
Fastening above ground	s. 6
Product information High Bench	s. 7
Product information High Bench sofa	s. 8
Product information High Bench coupling table	s. 9
Product information High Bench armrest	s. 10

High Bench möbelsystem

Overview

Ritad av Odin Sollie
Ritad datum 24-01-02

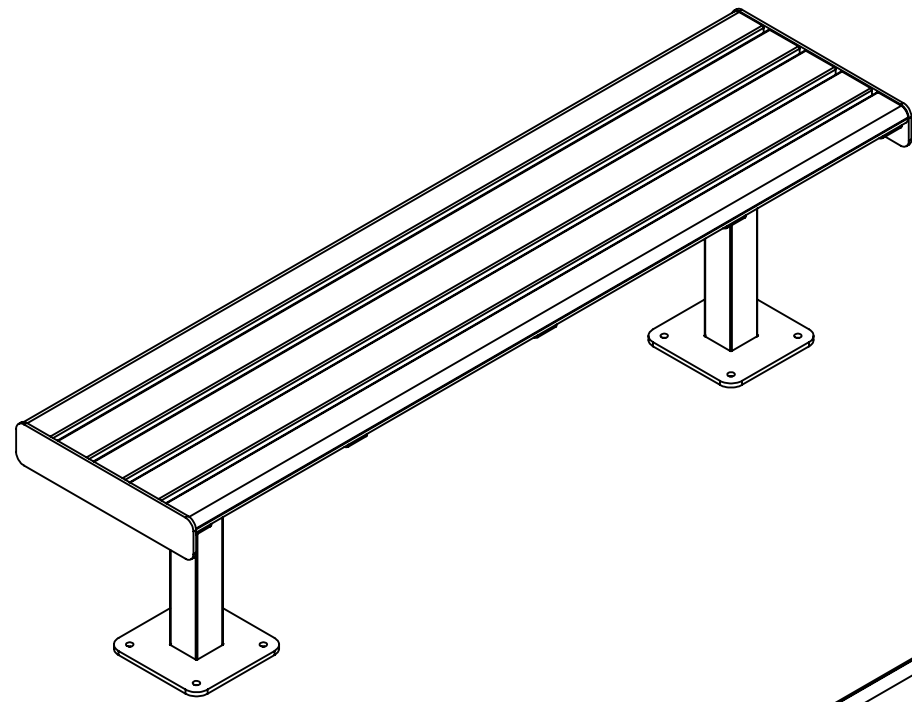

U11-55
High Bench

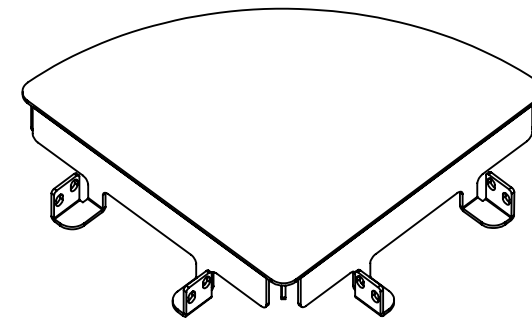

U11-55Arm
High Bench armrest

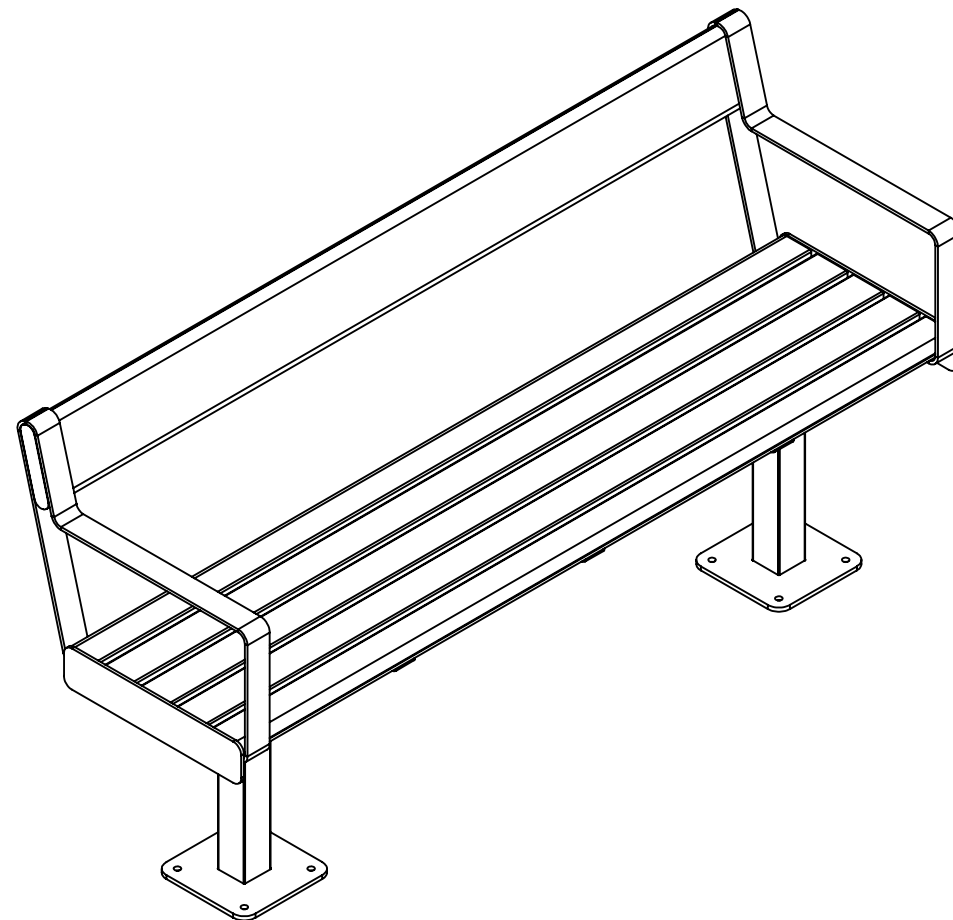

U11-55S
High Bench sofa

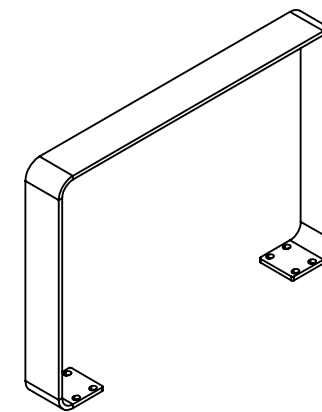

U11-55B
High Bench coupling table

High Bench furniture system

Assembly order

Ritad av Odin Sollie
Ritad datum 24-01-02

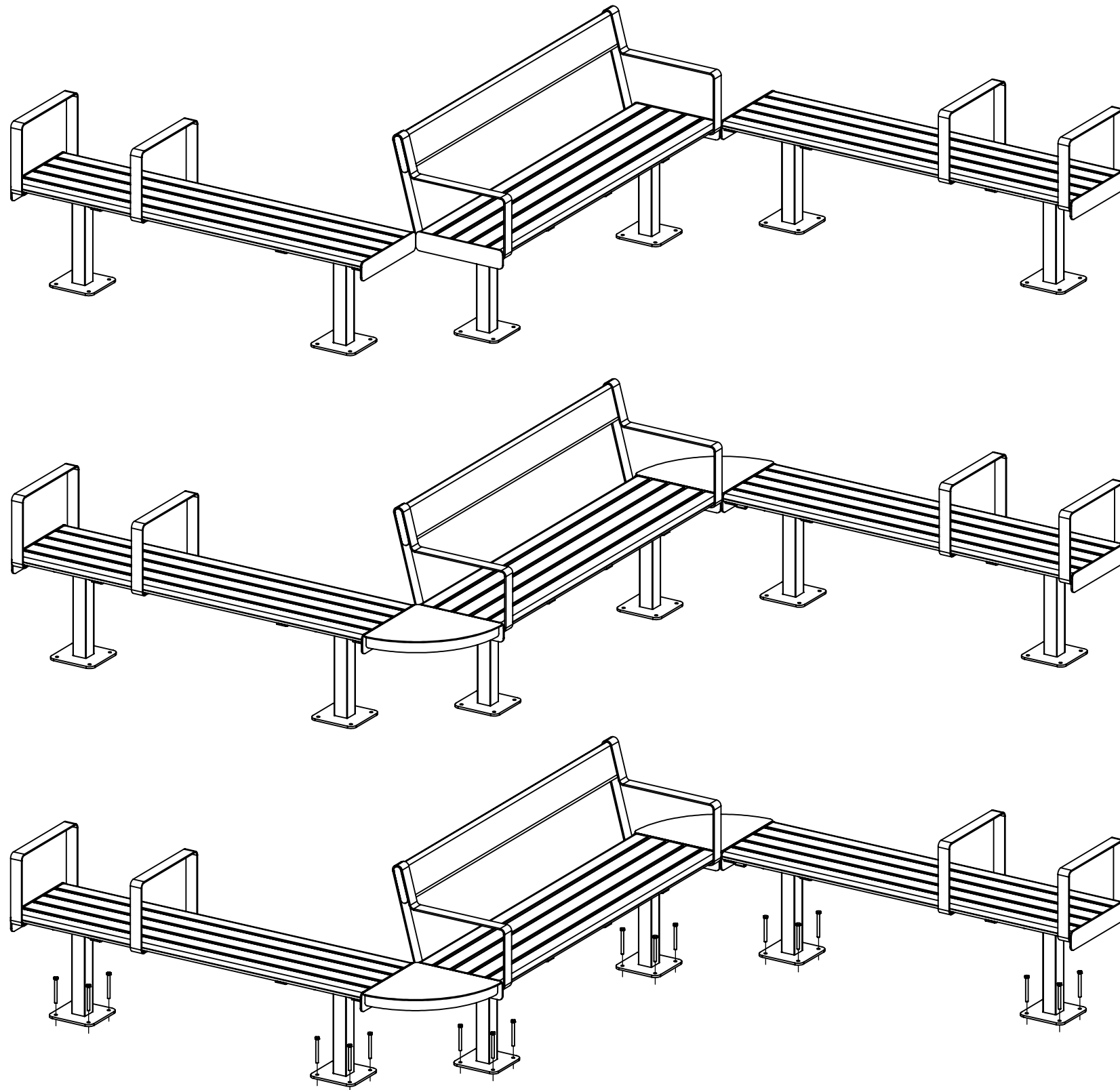

Assembly order

It's crucial that the High Bench furniture system is assembled in the correct order since the tables have small margins and might not be mountable at all if done last.

If the furniture system is to be bolted to a cast foundation, these can be cast first. The center-to-center distance between legs within benches and between benches with tables can be seen on page 6.

Attach leg frames to the seats following the instructions on page 4.

Arrange benches and sofas as they should be positioned with coupling tables in between on the designated site, i.e., on the foundations.

Attach the coupling tables and securely fasten them following the instructions on page 5.

Mark all holes of the leg frames or drill the foundations directly through the holes and secure the benches. Take care not to damage the paint on the base plates.

If the holes require additional preparation, lift off the entire bench combination and then place it back in the same position before fastening.

High Bench furniture system

Attaching legs

Ritad av Odin Sollie
Ritad datum 24-01-02

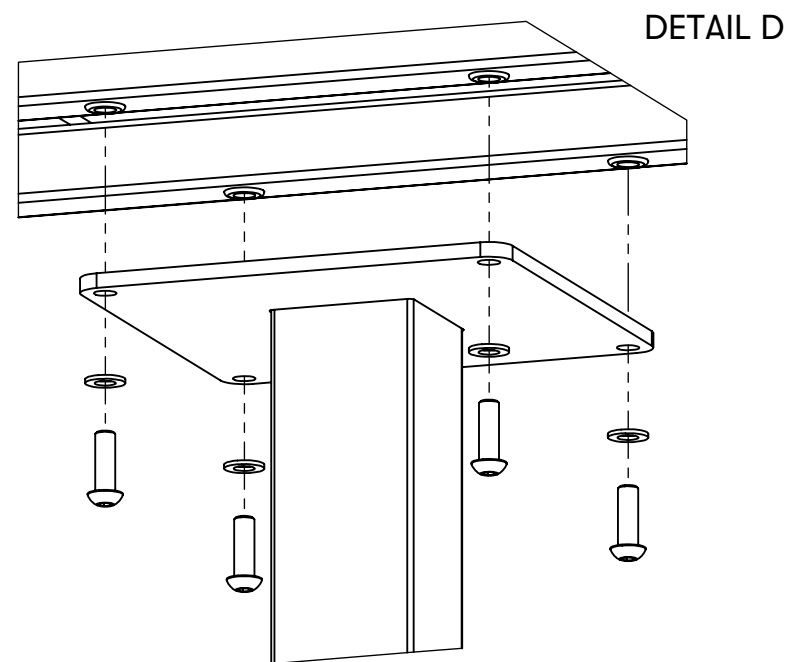
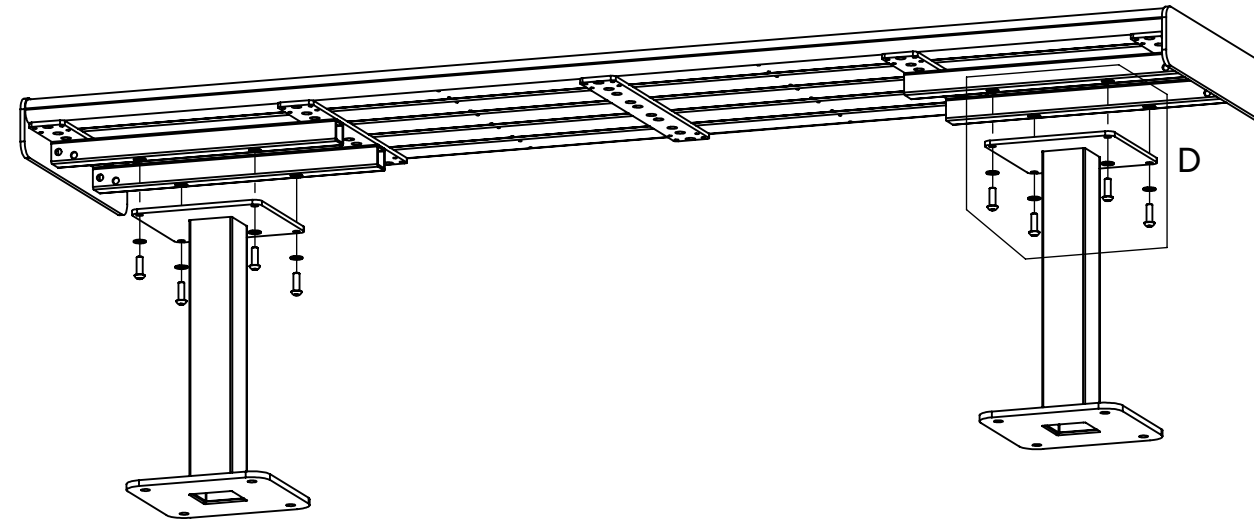

Attaching legs

The benches and sofa seats come with accompanying leg frames disassembled.

The leg frames are screwed onto the square tubes on the underside of the seats using 4 included M8x20 mm bolts per leg top + washers.

High Bench furniture system

Attaching coupling table

Ritad av Odin Sollie
Ritad datum 24-01-02

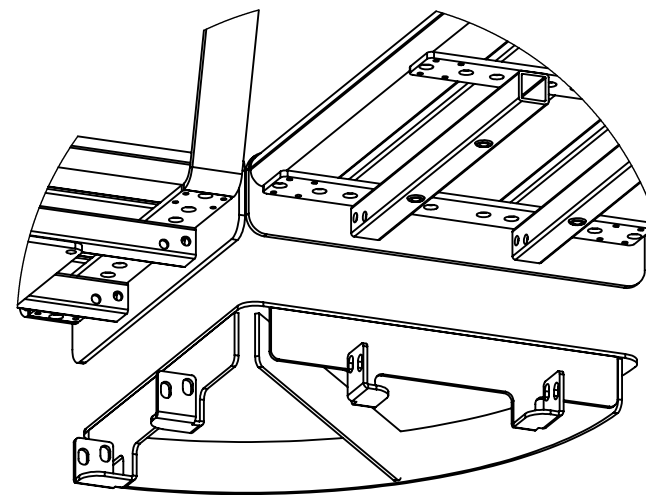
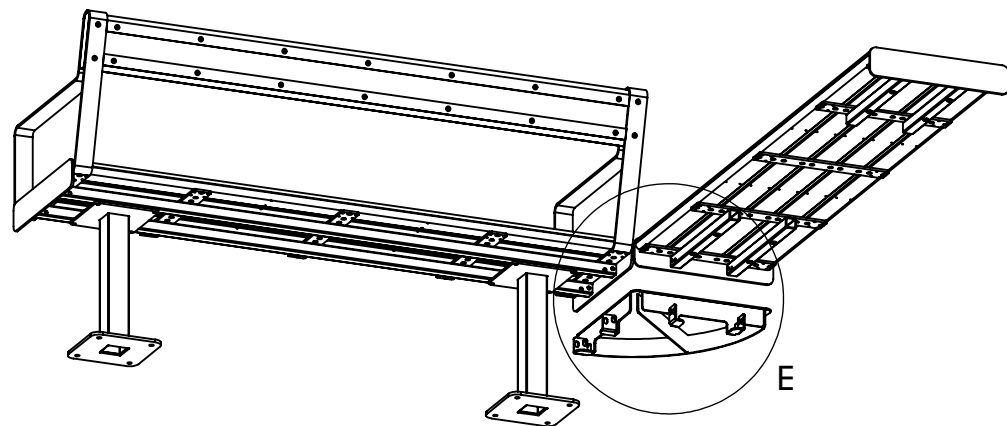

DETAIL E

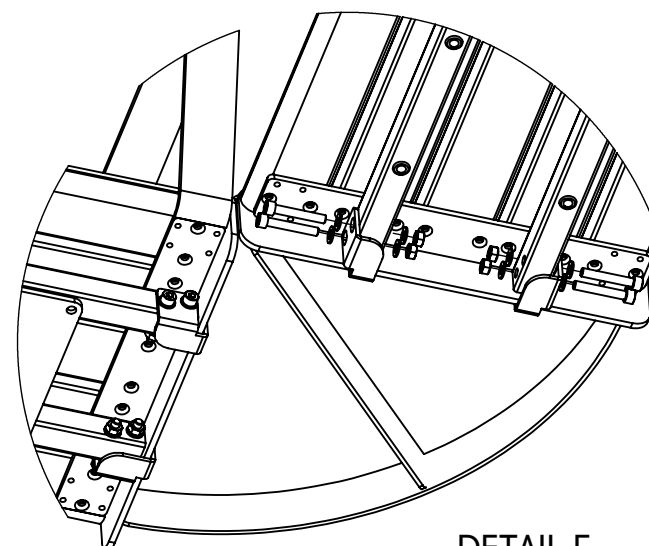
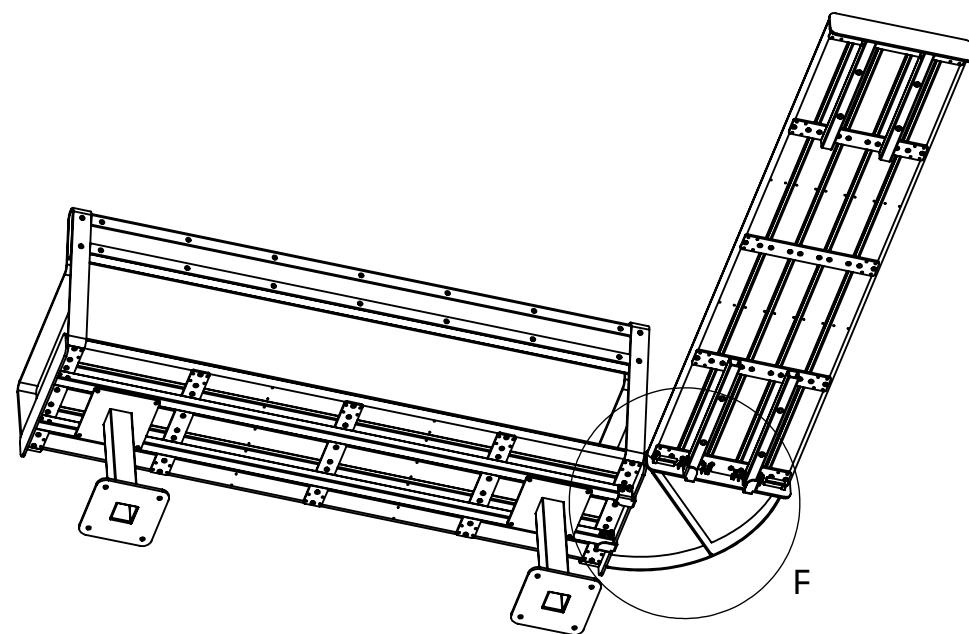

DETAIL F

Attaching coupling table

The coupling table is preferably assembled when the legs are attached to the seats so that the benches can stand on their own.

Position the benches or sofas at a 90-degree angle so that the steel gables almost touch each other in the inner corner. Lift the table from below so that it fits in place with the angled steel outside the square tubes.

Attach the angled steel to the tubes using the provided M8x50 screws, washers, and nuts through the holes. Tighten only after the table is adjusted to the same height as the seats.

The table can also be temporarily assembled on just one bench or sofa while waiting for another to connect.

High Bench furniture system

Fastening

Ritad av Odin Sollie
Ritad datum 24-01-02

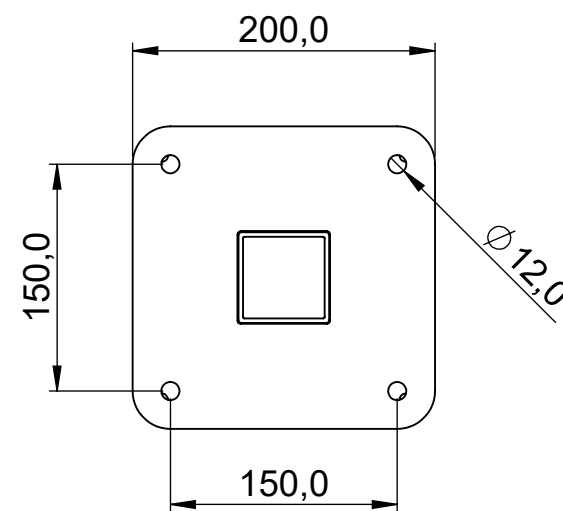
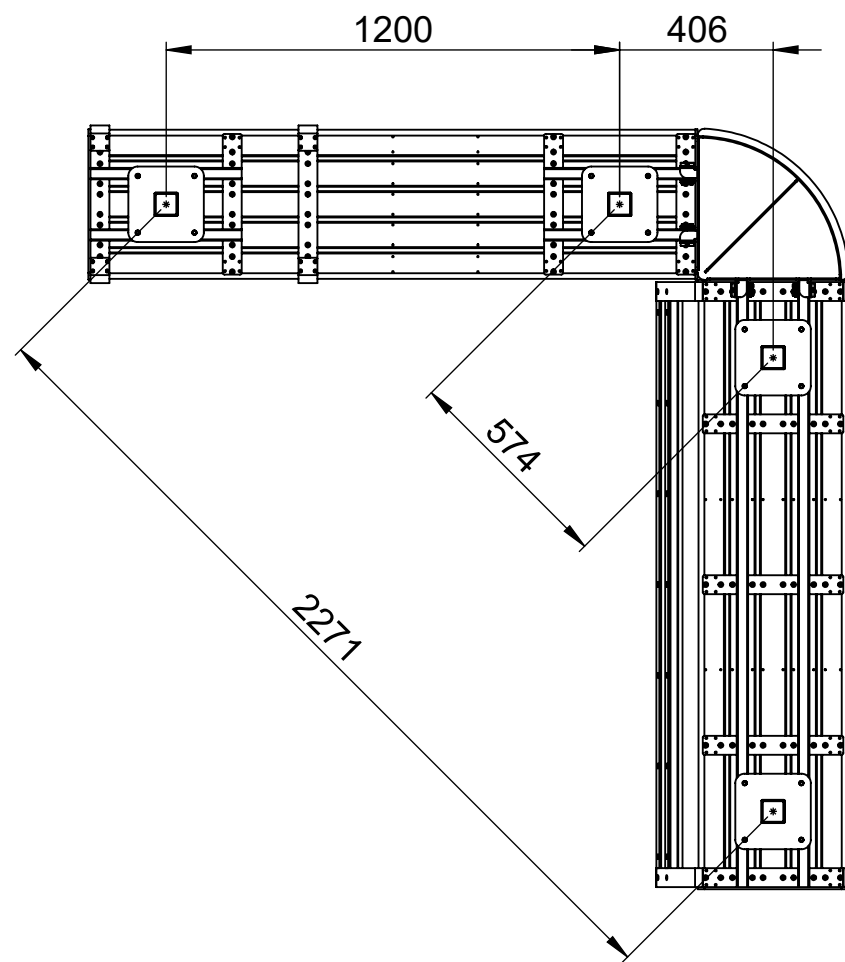
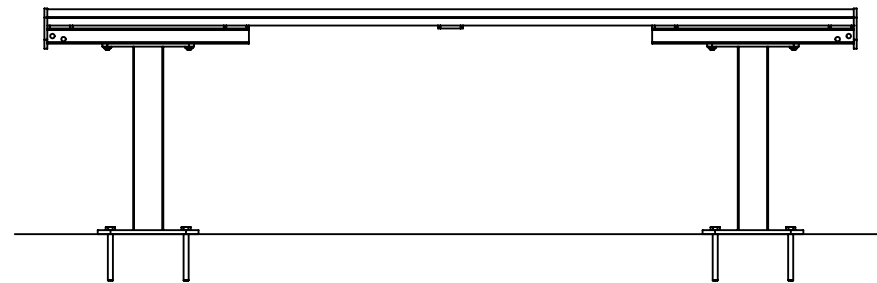

Fastening

The bench and sofa come with perforated base plates for fastening using 4 pcs M10 screws per base plate.

Fastening on wooden surfaces

Fasten using lag screws against the wooden surface.

Fastening on cobblestone or paving slabs

Fill underneath the slabs with concrete. There should be no bedding sand between the slabs and the concrete. Drill the concrete and the slab for expansion or chemical anchors.

Fastening on concrete or stone blocks, etc.

Fasten using chemical anchors or expansion anchors. Mounting with expansion anchors allows for detachable fastening.

High Bench furniture system

High Bench

Ritad av Odin Sollie
Ritad datum 24-01-02

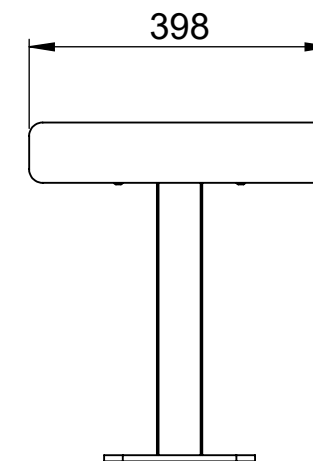
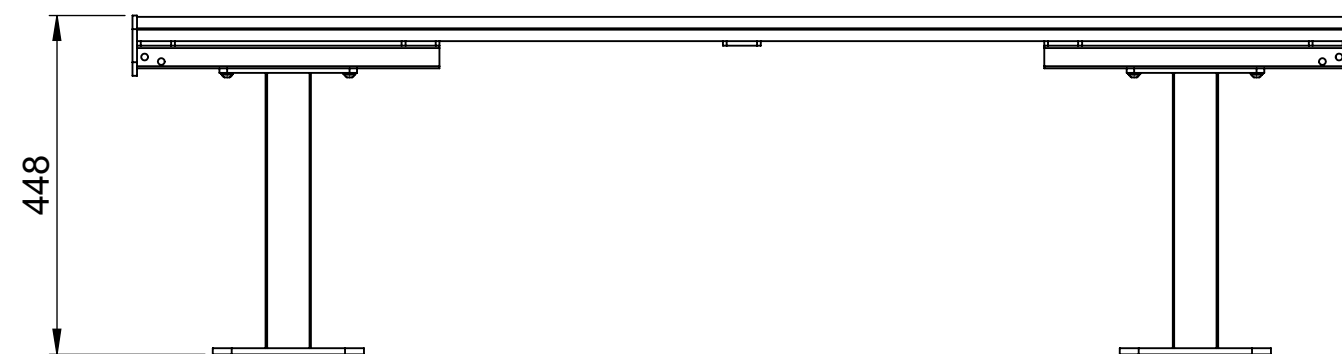
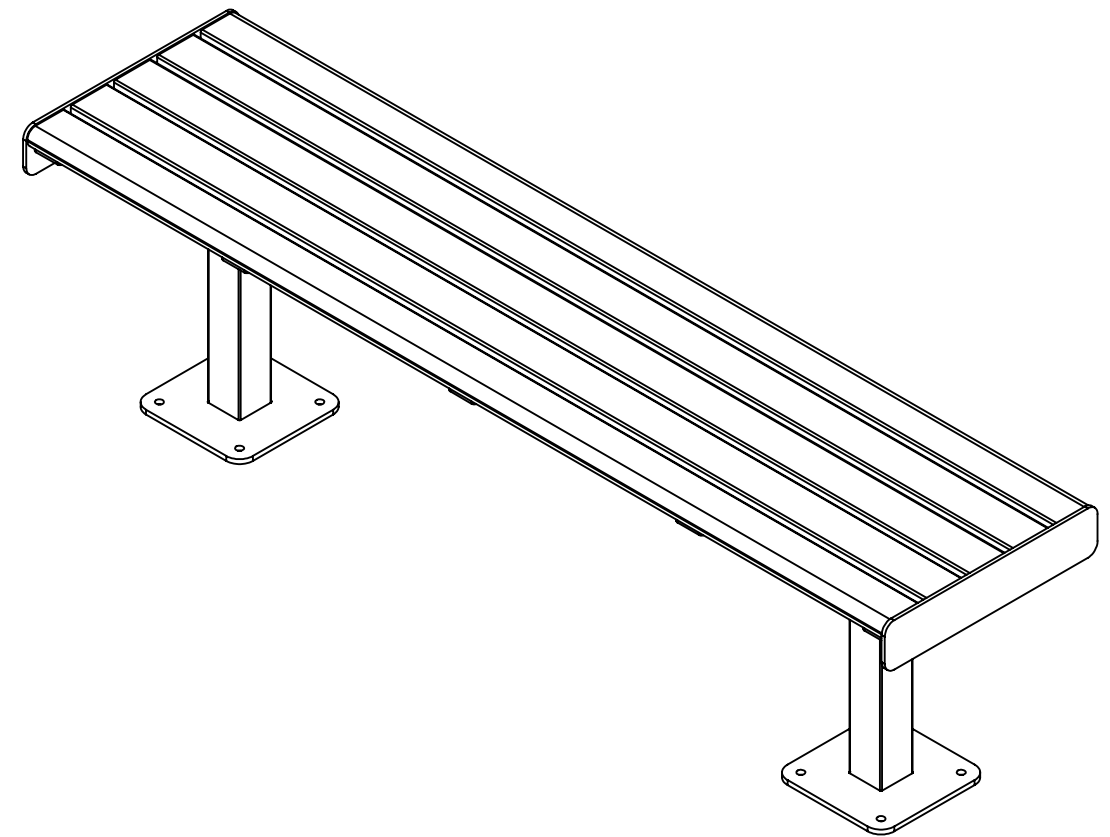
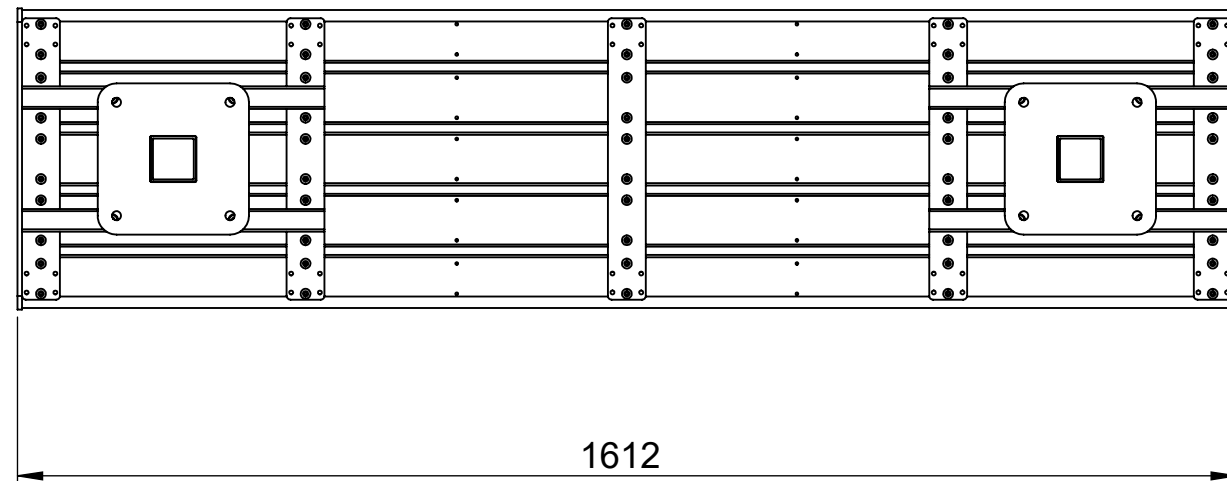

U11-55 High Bench

Includes one seat, 2 legs, and 8 pcs of M8x20 mm screws, washers, and nuts.
Weight: 36 kg.

High Bench furniture system

High Bench Sofa

Ritad av Odin Sollie
Ritad datum 24-01-02

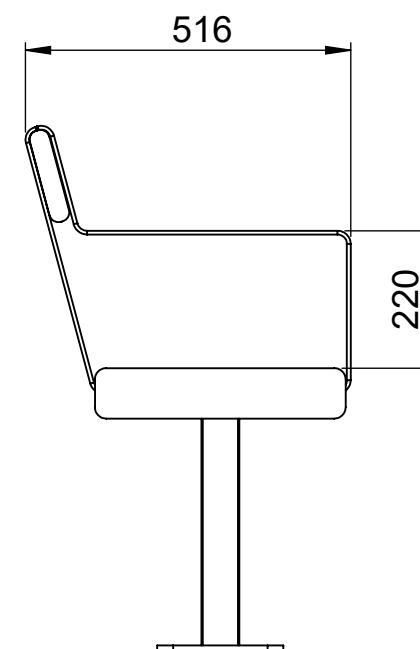
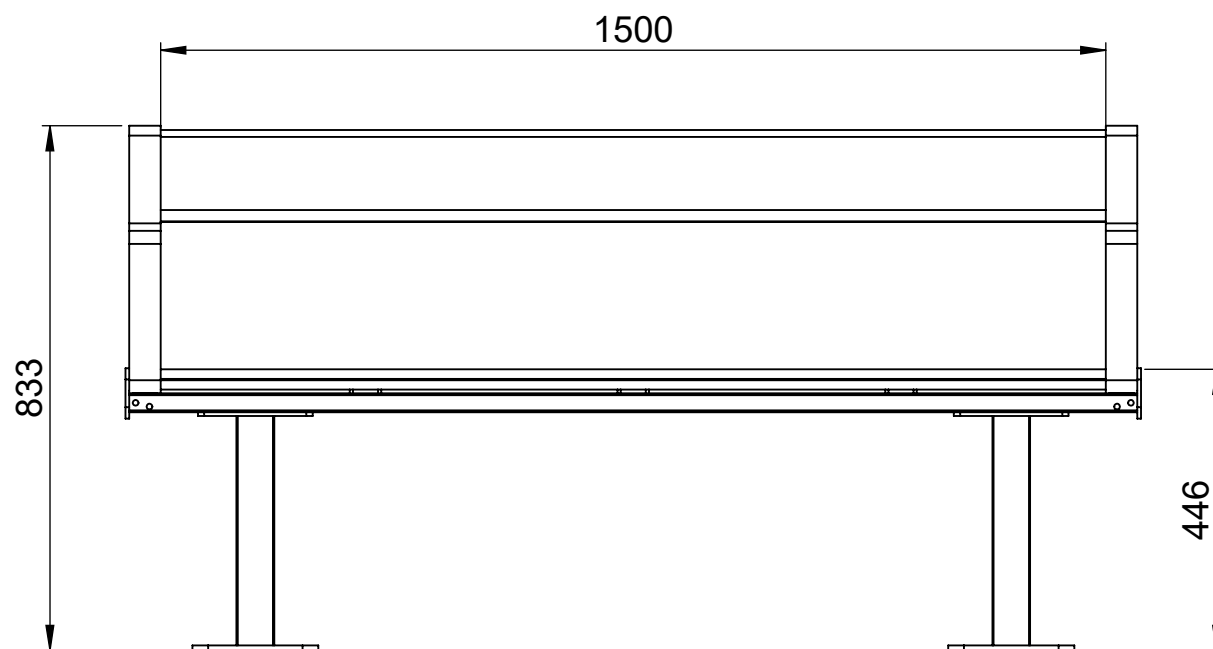
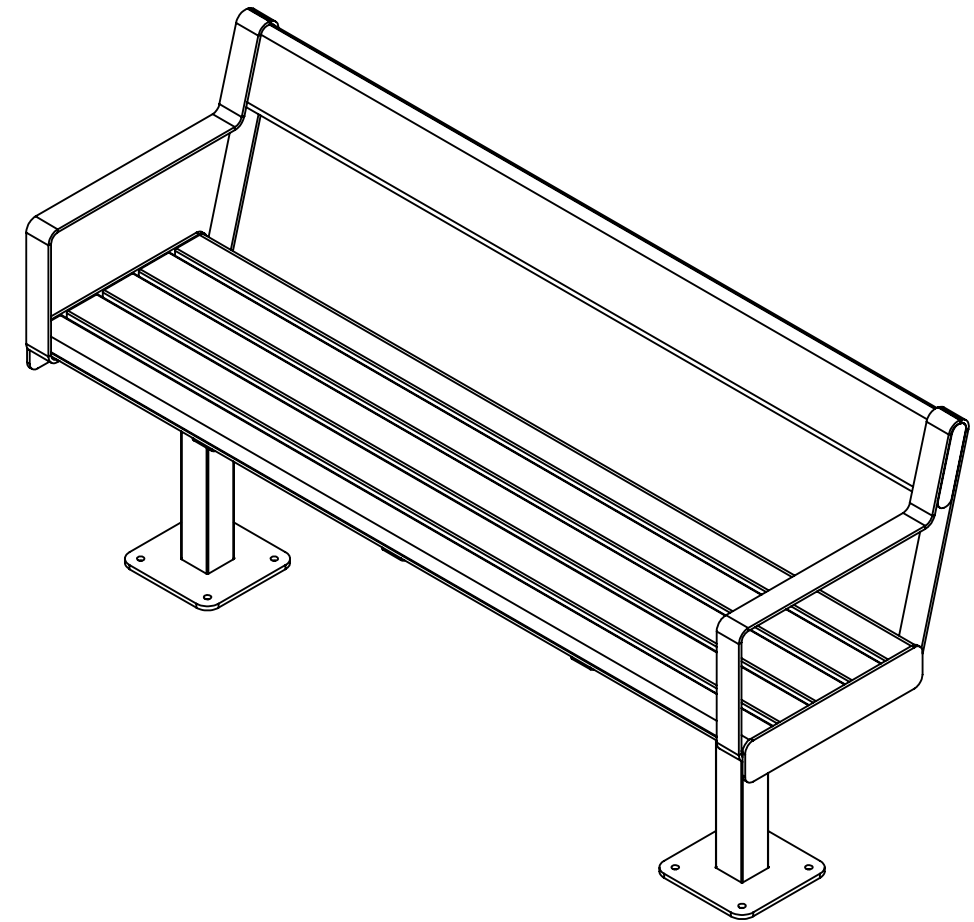
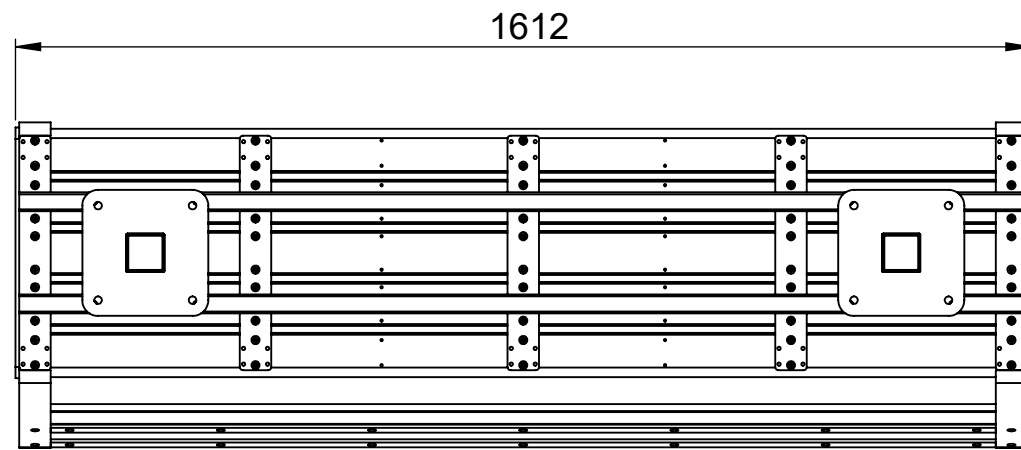

U11-55S High Bench sofa

Includes one seat, backrest, armrests, 2 legs, and 8 pcs of M8x20 mm screws, washers, and nuts.
Weight: 52 kg.

High Bench furniture system

High Bench coupling table

Ritad av Odin Sollie
Ritad datum 24-01-02

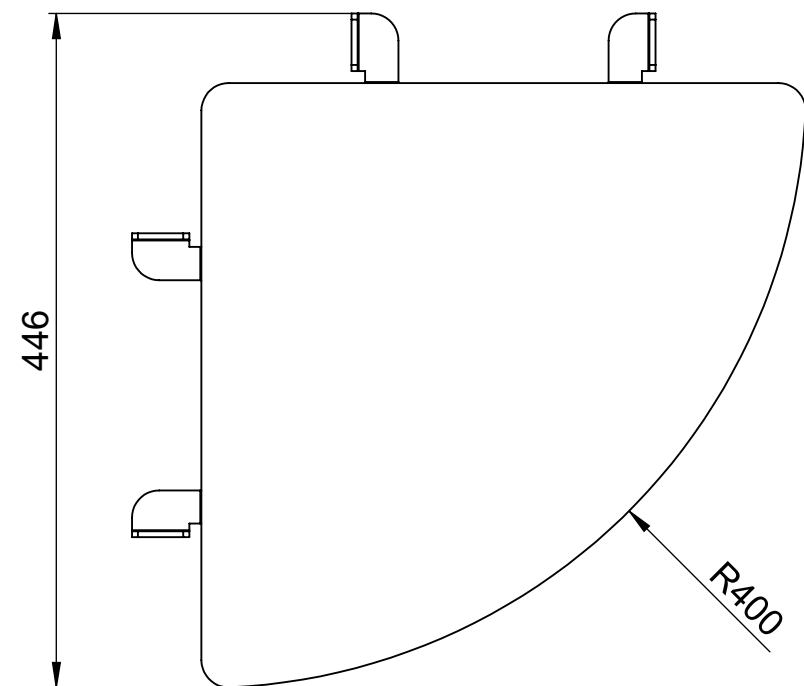
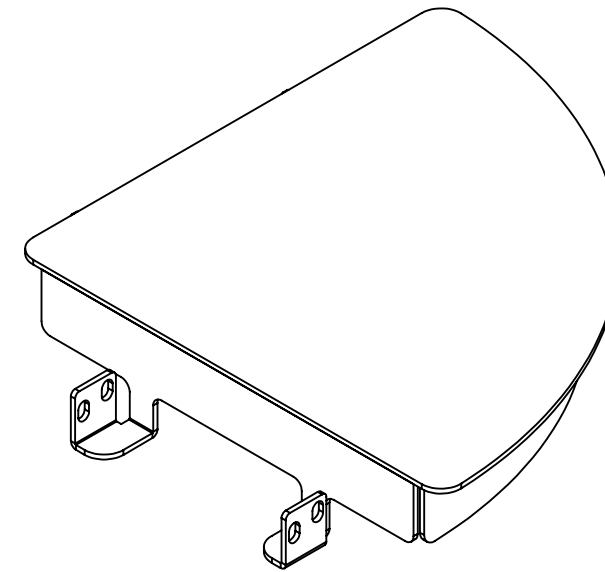
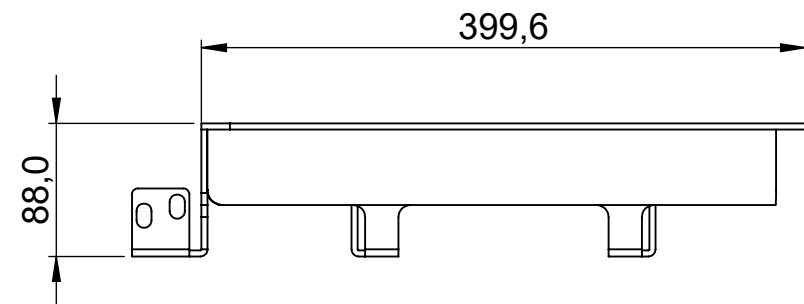

U11-55B High Bench coupling table

Includes 4 pcs of M8x50 mm bolts with washers and nuts for assembly on two benches or sofas.

Weight 7 kg

High Bench furniture system

High Bench armrest

Ritad av Odin Sollie
Ritad datum 24-01-02

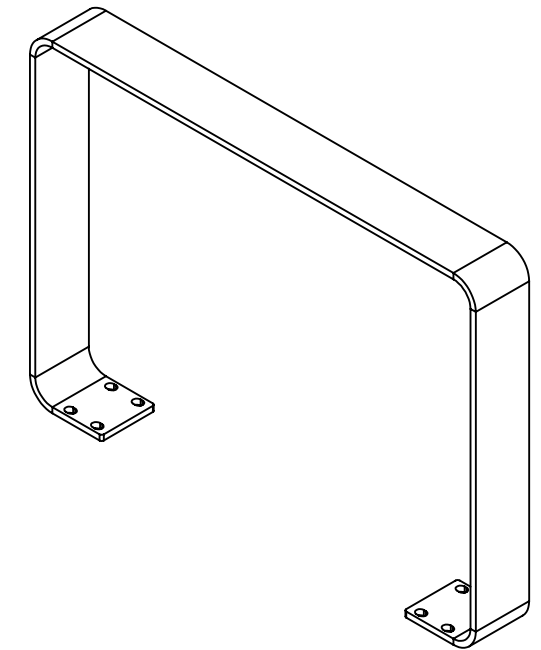
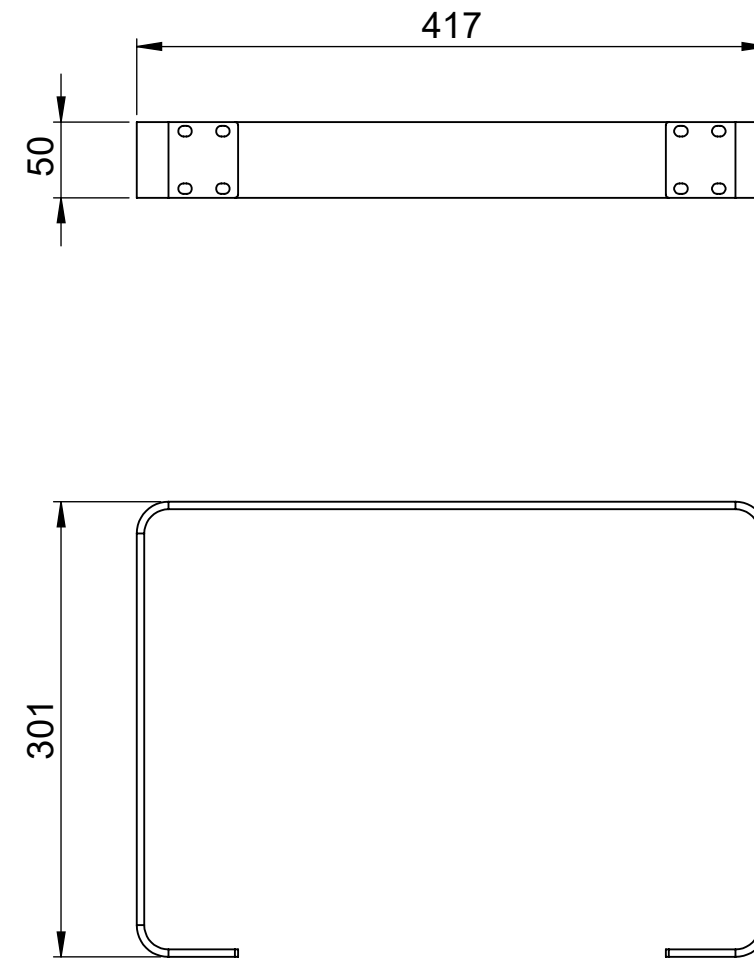
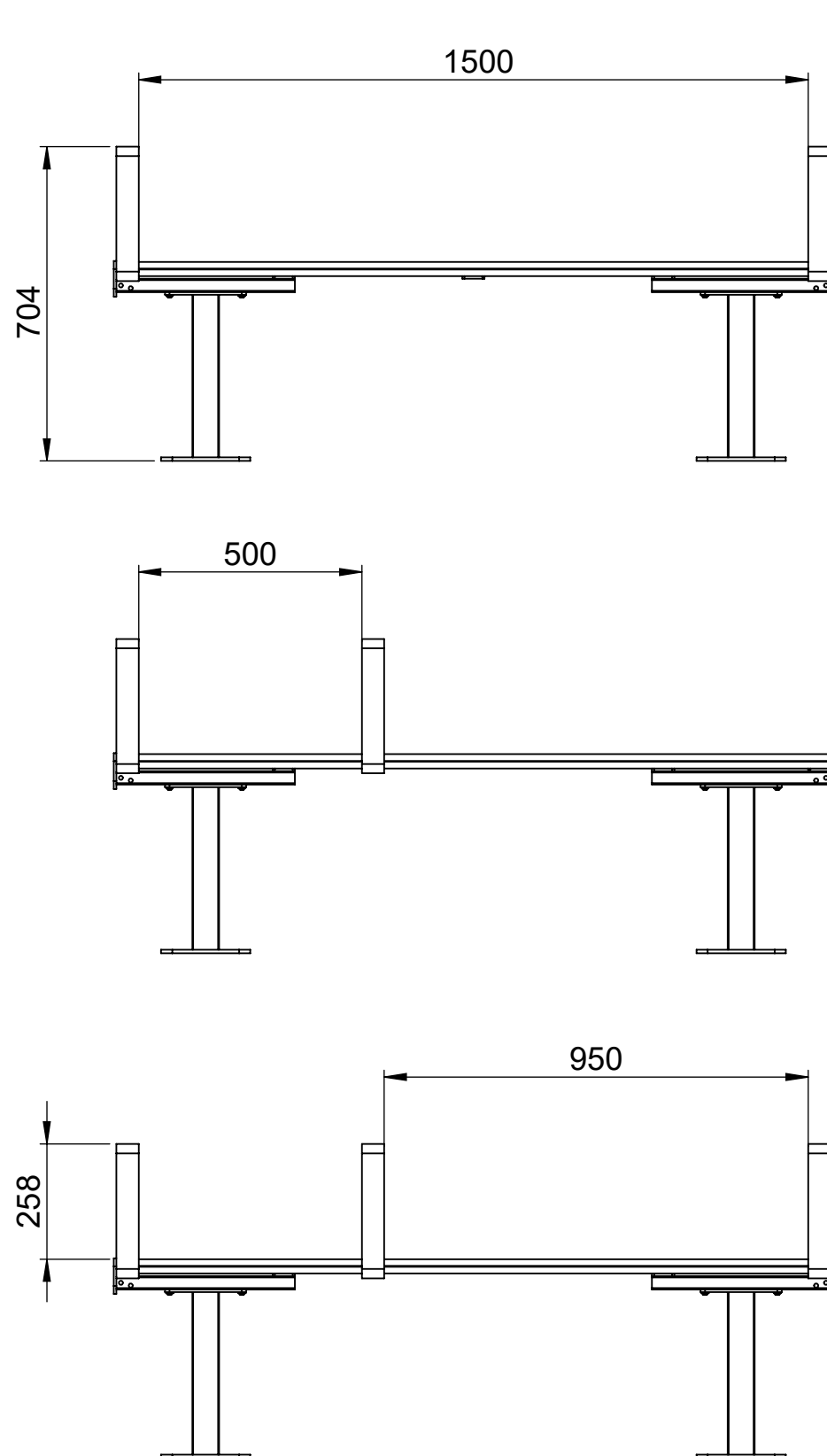

U11-55 Arm High Bench armrest

When armrests are ordered, they come pre-assembled on the seat. Specify the location on the seat where they should be placed. On the left, an example is shown of how 2-3 armrests can be positioned on a bench.

Weight: 2 kg.