

A= Stolpe med konsol för infästning av bänksits 8 st

B= Stolpe utan konsol 2 st

C= Topp bricka 1 st

Ö70-13= Sirius spaljé C-C 99 cm höjd 159 cm 6 st

Ö70-14 = Sirius spaljé C-C 99 cm Höjd 98 cm 6 st

Ö1= Överliggare 12 st

H1= Högben 12 st

T1= Takskiva 12 st

T2 = Toppkon 1 st

BY = Bänksits ytter 4 st

BM = Bänksits mitt 2 st

Huset är förberett för plåttak. Underlagspapp bifogas leveransen. Täckpapp kan erhållas mot förfråga.

Stolprna gjuts i mark eller monteras i prefab fundament, MEAG 108-114 Fundament ingår inte i leveransen.

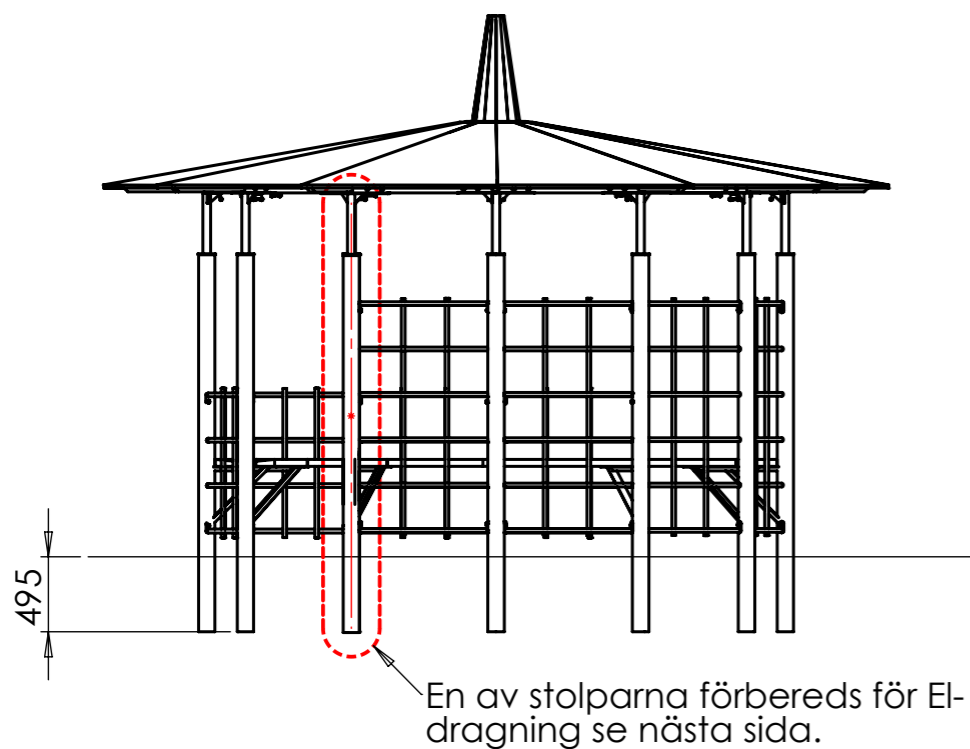
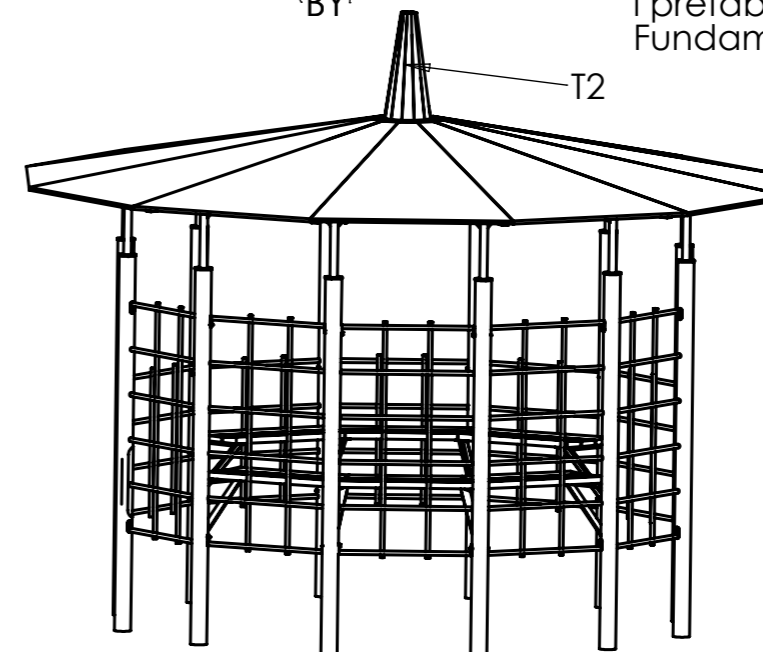

TITLE: Sammanställning

DWG NO. Orion Lusthus

A3

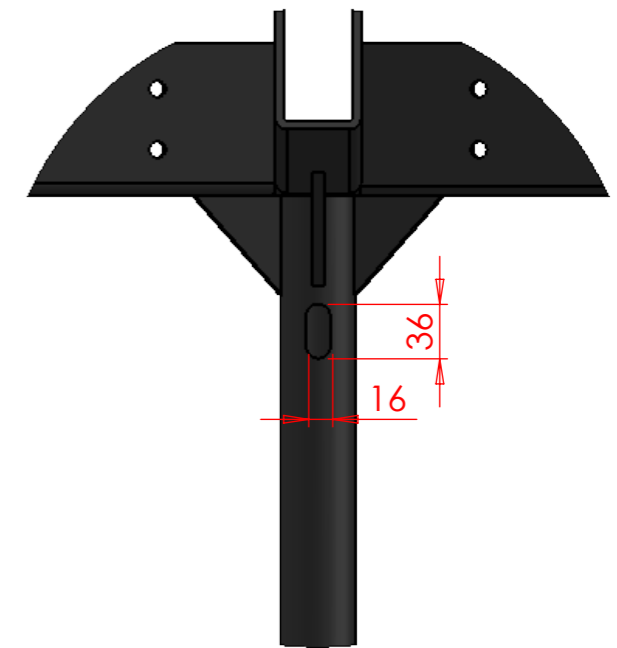
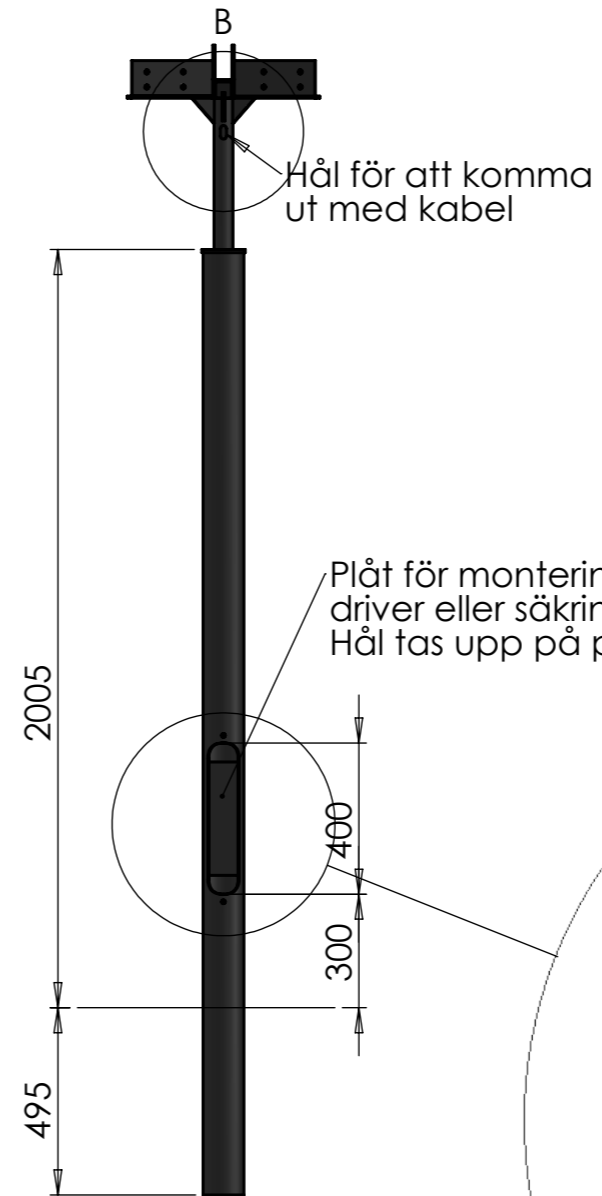

DETAIL B  
SCALE 1 : 5

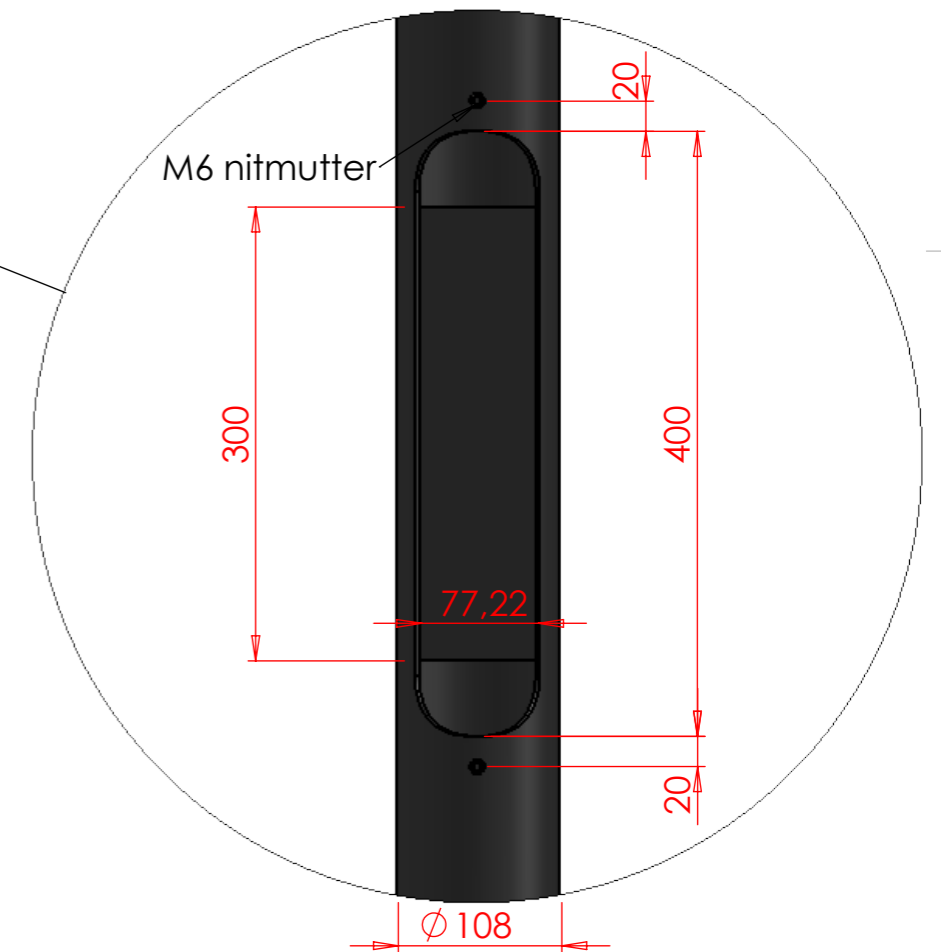

DETAIL A  
SCALE 1 : 5

MATERIAL		YTFINISH		BESKRIVNING Elstolpe Orion		
RITAD AV		DATUM 2020-09-24	STORLEK A3	PROD. NR.	FILNAMN Orion sammanställning	REV.
KONTROLLERAD AV		DATUM	SKALA 1:20	FORMGIVARE		BLAD 2 av 3

BM

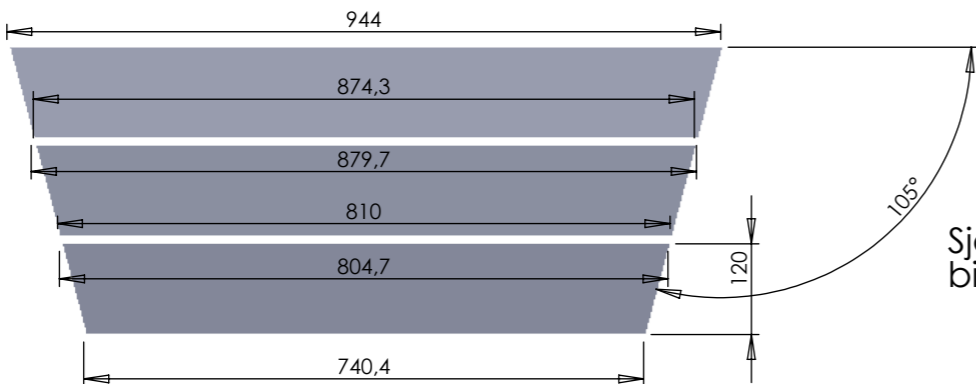

Självborende 6 mm träskruv bifogas för montering av bänkarna.

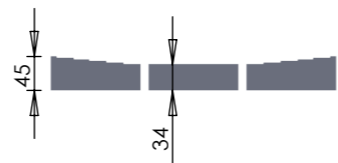

Den här delen fasas och anpassas till toppbrickan.

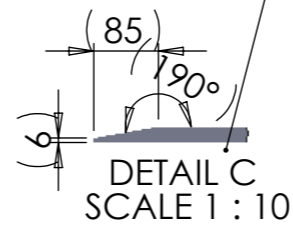

BY

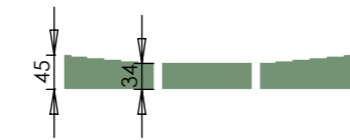
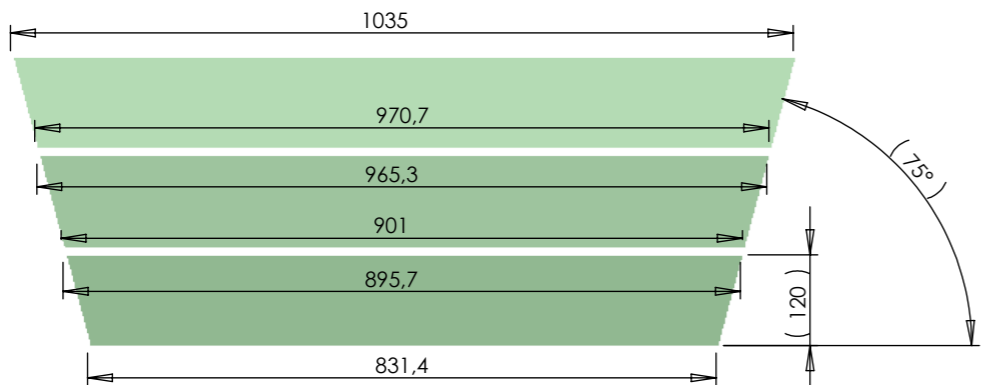

500 trallskruv bifogas leveransen.

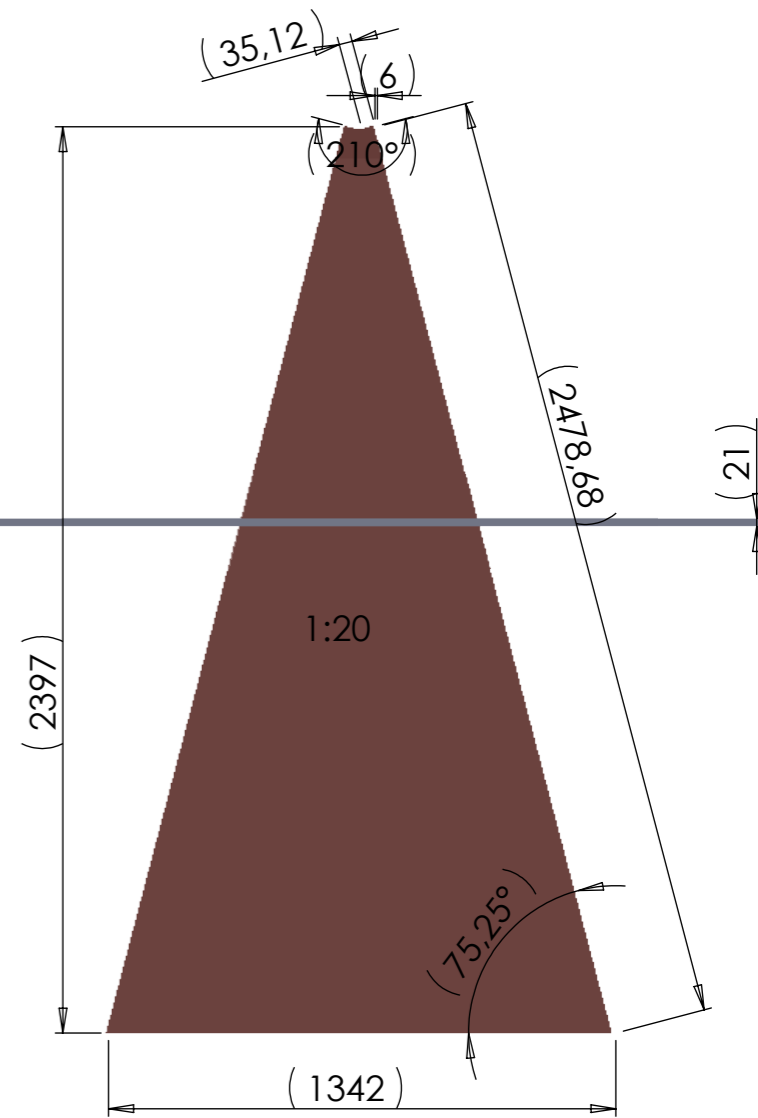
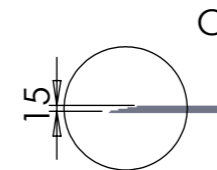

Ö1

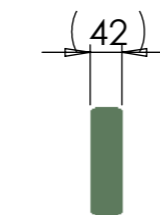
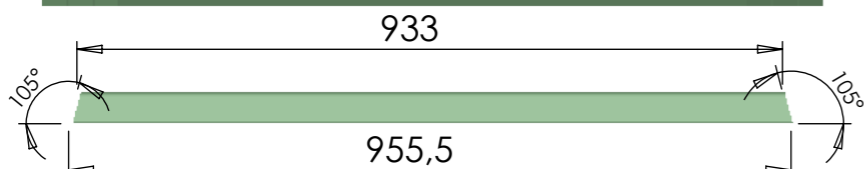

Hål görs i överliggaren för vagnsbult M10.

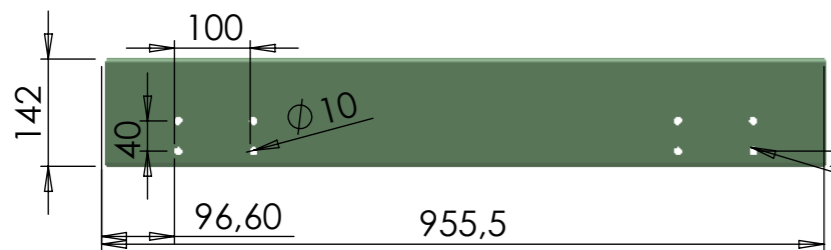

H1

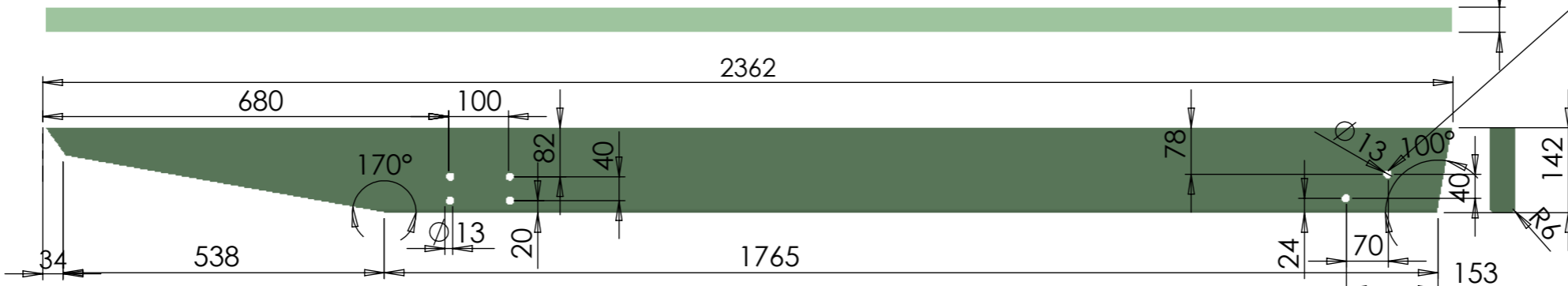

Genomgående hål Ø13 för bult M10 x 65 skruvas med mutter och bricka.

TITLE:	Trädetaljer	
DWG NO.	Orion Lusthus	A3
Skala:1:10	Sign. UH 2009-10-28	Blad 3 av 3