



Main Office Stockholm

Nola Industrier AB  
Box 17701  
Repslagargatan 15b  
118 93 Stockholm  
Tel: 08-702 1960  
Fax: 08 702 1962  
headoffice@nola.se

Sales Office/Showroom Malmö

Nola Industrier AB  
Skeppsbron 3  
211 20 Malmö  
Tel: 040 171 190  
order@nola.se

[www.nola.se](http://www.nola.se)

Overview, furniture group.....page 2  
Installation.....page 3  
Product information Big Basket.....page 4  
Product information Small Basket.....page 5  
Product information Mini Basket.....page 6  
Product information Big Basket table.....page 7

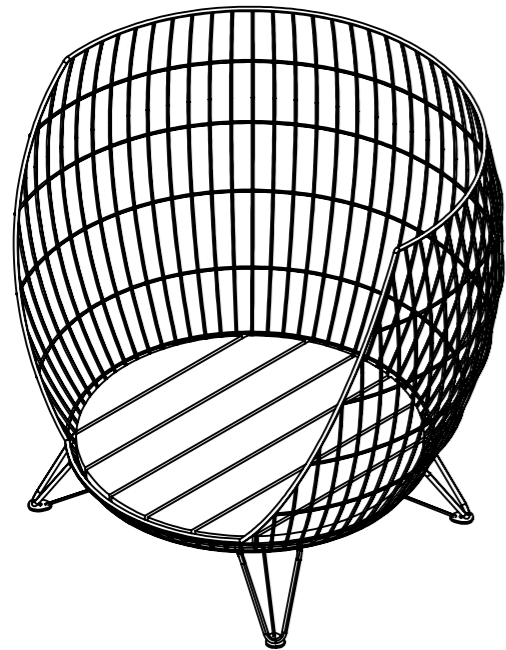

U12-08 Big Basket  
U12-08SITS Big Basket Seat

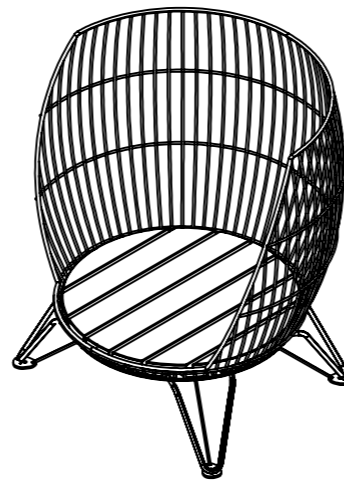

U12-10 Mini Basket  
U12-10SITS Mini Basket Seat

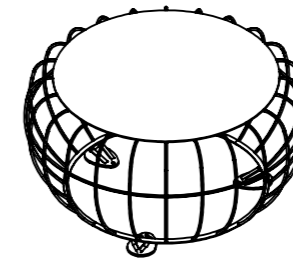

U12-09 Big Basket table

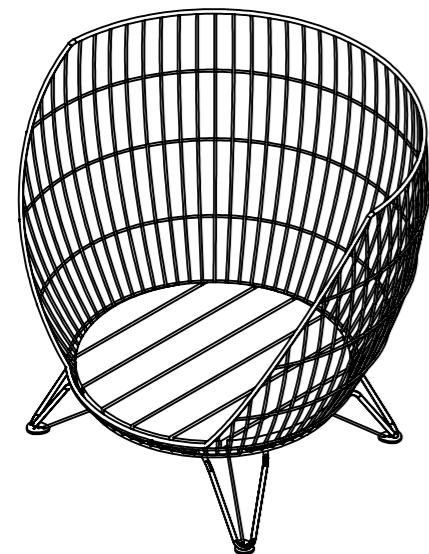

U12-06 Small Basket  
U12-06SITS Small Basket Seat

Obeserve that seats are ordered separately from chairs, material choice code is obligatory

/TYG for cloth seat in cold foam, inclusive upholstering labor, exclusive fabric cost, Indoor

/KOKOS for cloth seat in coconut latex, inclusive upholstering labor, exclusive fabric cost, Indoor

/DRY for cloth seat in dry foam, inclusive upholstering labor, exclusive fabric cost, Outdoor

/ACC for wooden seat in Accoya, Outdoor

/EK for wooden seat in oak, Outdoor

# nola®

Main Office Stockholm

Nola Industrier AB  
Box 17701  
Repslagargatan 15b  
118 93 Stockholm  
Tel: 08-702 1960  
Fax: 08 702 1962  
headoffice@nola.se

Sales Office/Showroom Malmö

Nola Industrier AB  
Skeppsbron 3  
211 20 Malmö  
Tel: 040 171 190  
order@nola.se

[www.nola.se](http://www.nola.se)

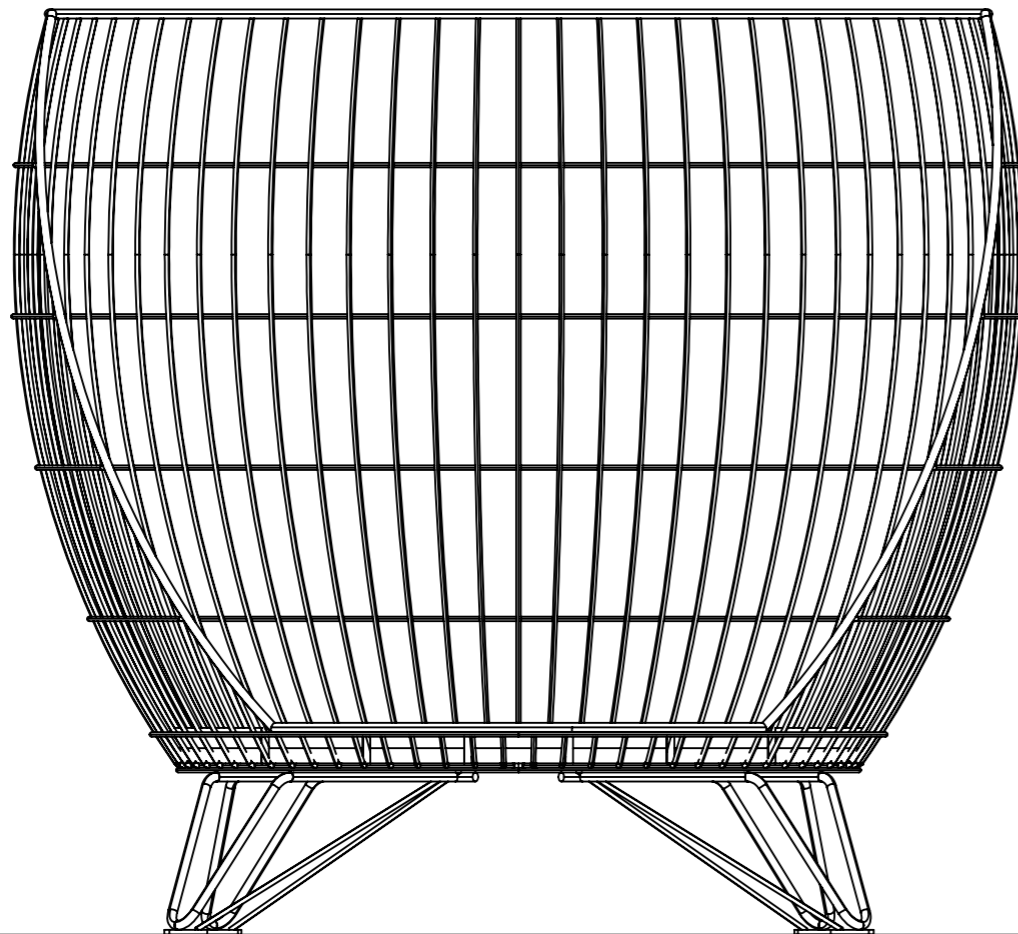

### Installation on ground

Chairs and table are completely free standing, but can be attached to ground if installed in an exposed area or if fire safety rules require it. All pieces in the group have foot plates for mounting with 4 M8 bolts. Hole pattern is shown on respective product information pages

### Mounting on wood surfaces

Predrill and install with wood screws

### Installation on paving stones

Install concrete footers under footplates. Drill footers for chemical anchors or expanders. Do not allow sand between footplates and footer when installing.

### Installation on concrete or solid stone

Install using chemical anchors or expanders  
Installation using expanders enable a removable attachment

# nola®

Main Office Stockholm

Sales Office/Showroom Malmö

Nola Industrier AB  
Box 17701  
Repslagargatan 15b  
118 93 Stockholm  
Tel: 08-702 1960  
Fax: 08 702 1962  
headoffice@nola.se

Nola Industrier AB  
Skeppsbron 3  
211 20 Malmö  
Tel: 040 171 190  
order@nola.se

www.nola.se

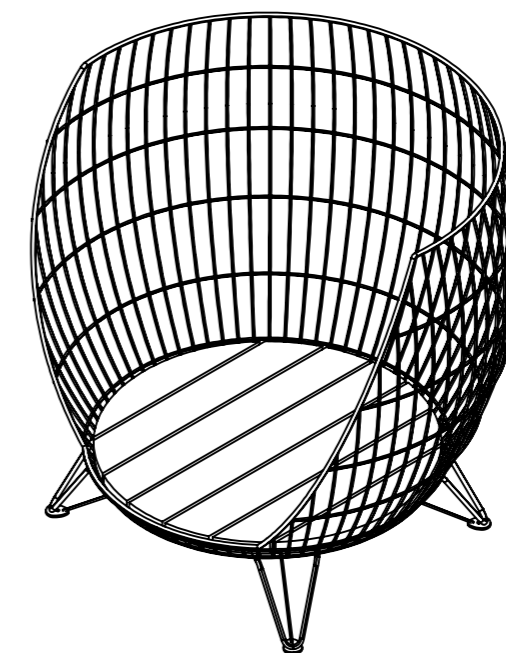
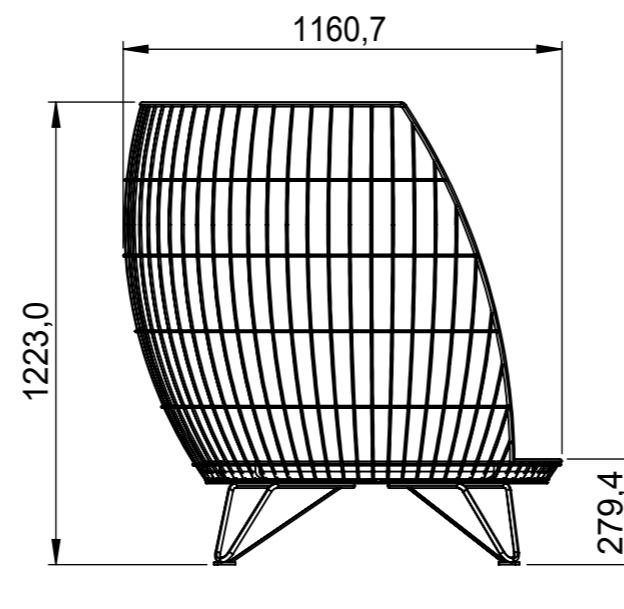
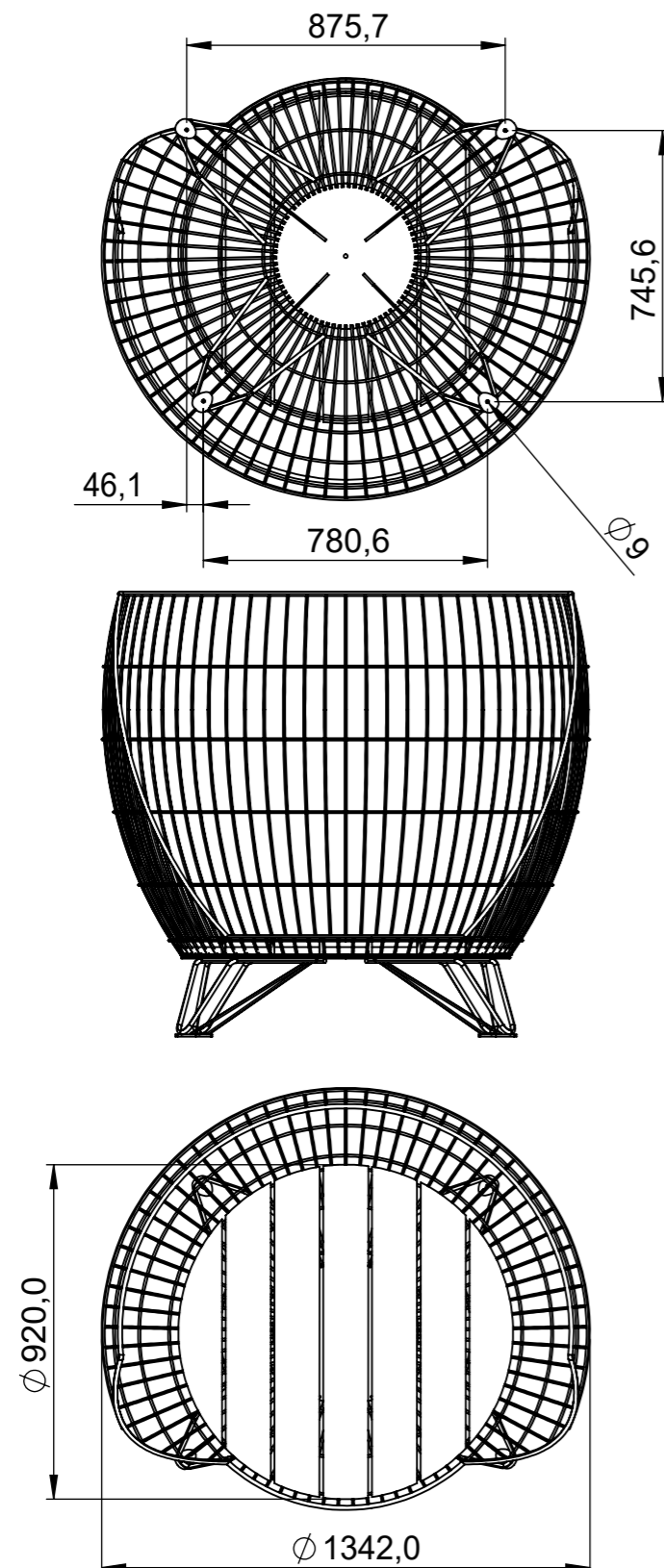

U12-08 Big Basket, exclusive seat

U12-08SITS Big Basket seat

Big Basket is delivered fully assembled with seat installed

Ritad av:  
Ritad datum:

Kollad av:  
Kollad datum:

Revision: A-01

# nola®

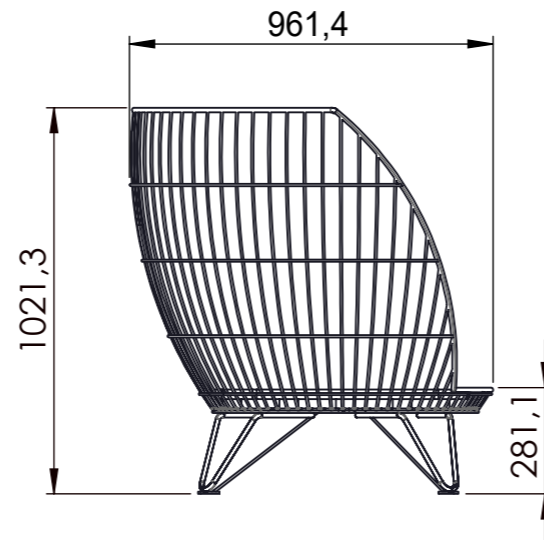
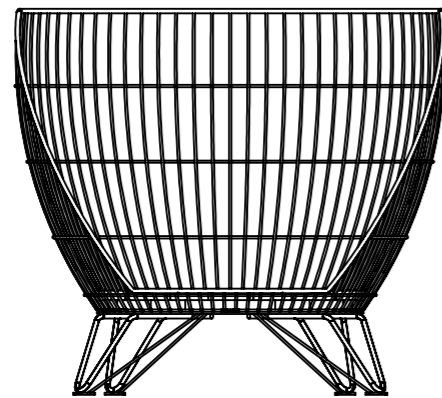
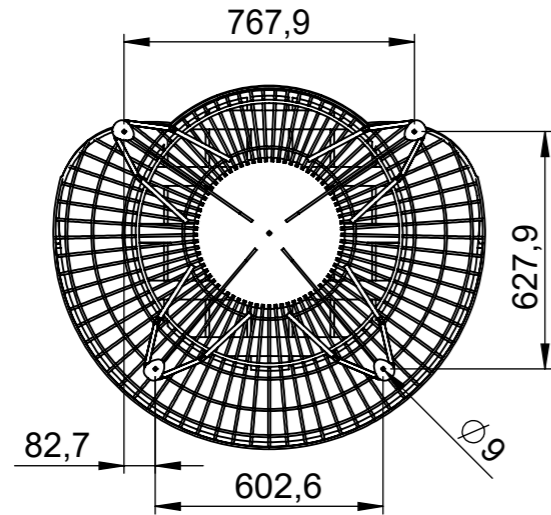

Main Office Stockholm

Nola Industrier AB  
Box 17701  
Repslagargatan 15b  
118 93 Stockholm  
Tel: 08-702 1960  
Fax: 08 702 1962  
headoffice@nola.se

Sales Office/Showroom Malmö

Nola Industrier AB  
Skeppsbron 3  
211 20 Malmö  
Tel: 040 171 190  
order@nola.se

www.nola.se

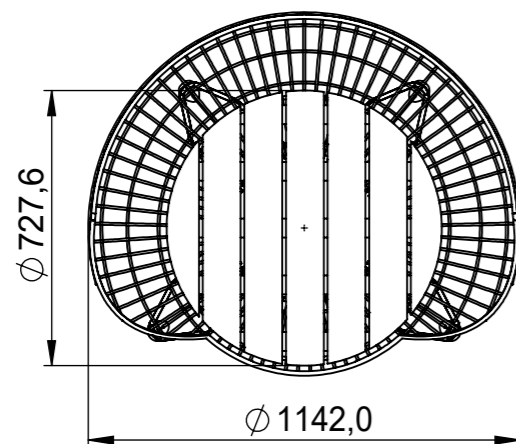
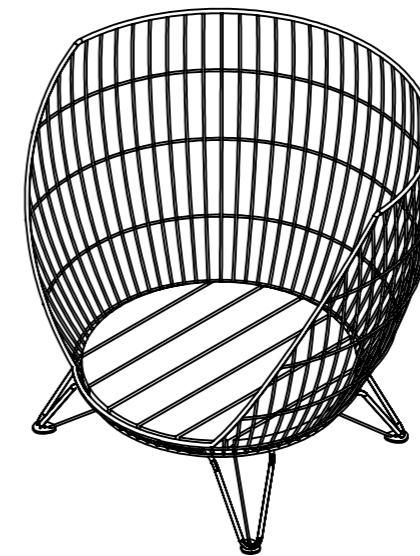

U12-06 Small Basket, exclusive seat

U12-06SITS Small Basket seat

Small Basket is delivered fully assembled with seat installed

# nola®

Main Office Stockholm

Sales Office/Showroom Malmö

Nola Industrier AB  
Box 17701  
Repslagargatan 15b  
118 93 Stockholm  
Tel: 08-702 1960  
Fax: 08 702 1962  
headoffice@nola.se

Nola Industrier AB  
Skeppsbron 3  
211 20 Malmö  
Tel: 040 171 190  
order@nola.se

[www.nola.se](http://www.nola.se)

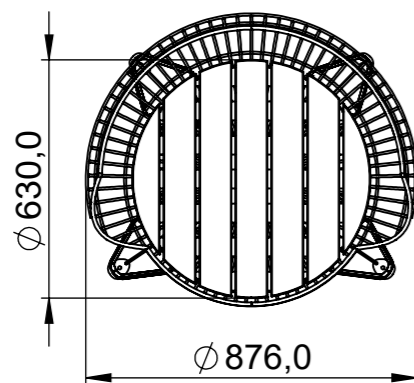
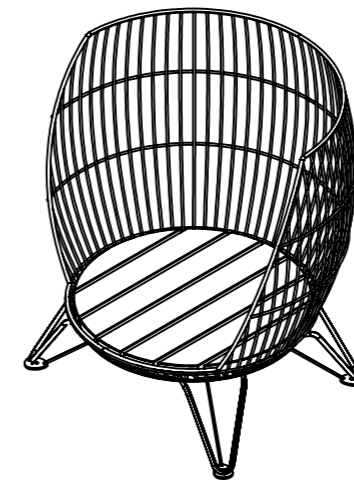
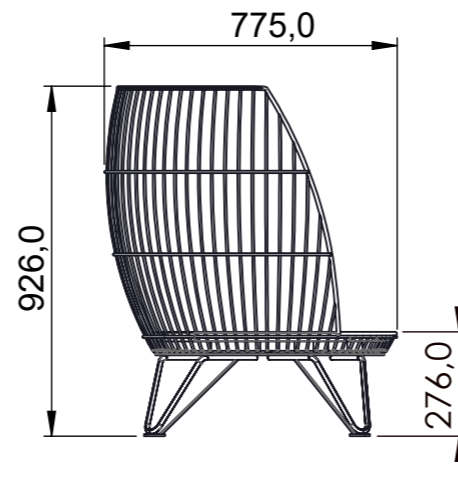
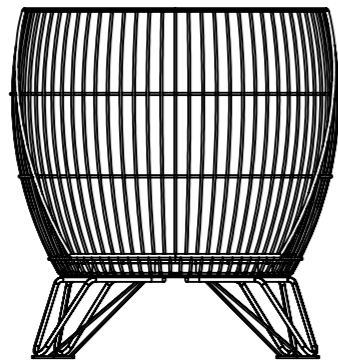
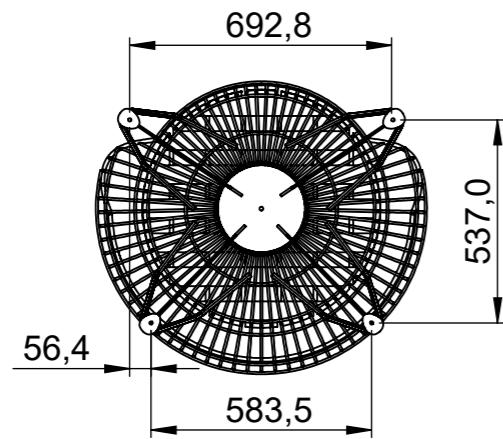

U12-10 Mini Basket, exclusive seat

U12-10SITS Mini Basket seat

Mini Basket is delivered fully assembled with seat installed

Ritad av:  
Ritad datum:

Kollad av:  
Kollad datum:

Revision: A-01

# nola®

Main Office Stockholm

Nola Industrier AB  
Box 17701  
Repslagargatan 15b  
118 93 Stockholm  
Tel: 08-702 1960  
Fax: 08 702 1962  
headoffice@nola.se

Sales Office/Showroom Malmö

Nola Industrier AB  
Skeppsbron 3  
211 20 Malmö  
Tel: 040 171 190  
order@nola.se

www.nola.se

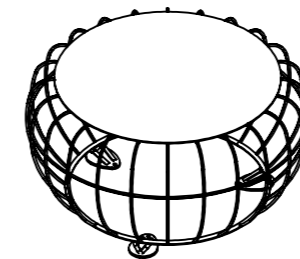
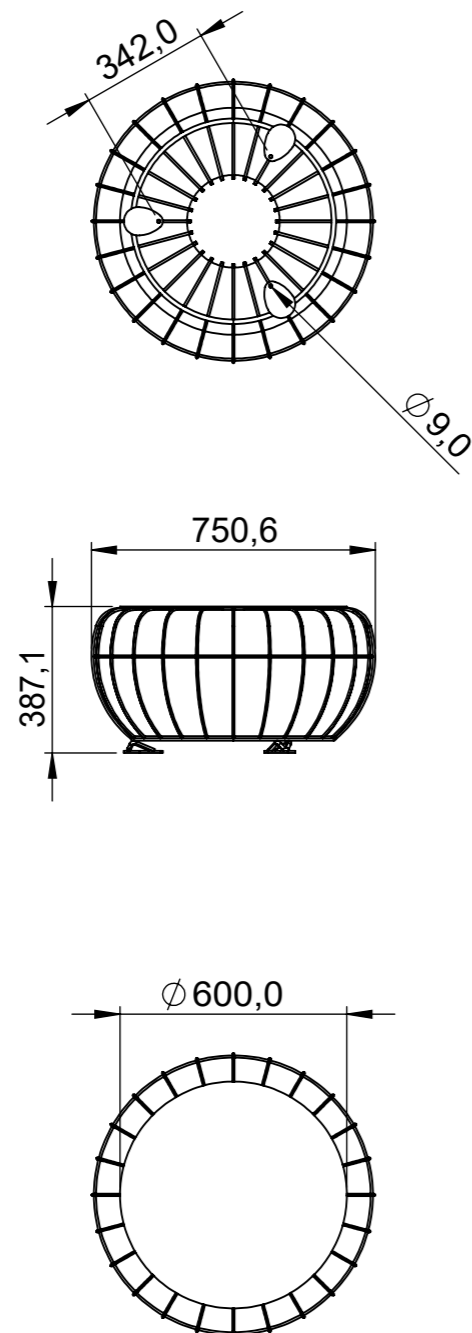

U12-09 Big Basket table

Big Basket table is delivered fully assembled with seat installed

Ritad av:  
Ritad datum:

Kollad av:  
Kollad datum:

Revision: A-01