

Kebne Sign

Product overview

Ritad av Joachim Henriksson
Ritad datum 2025-02-10

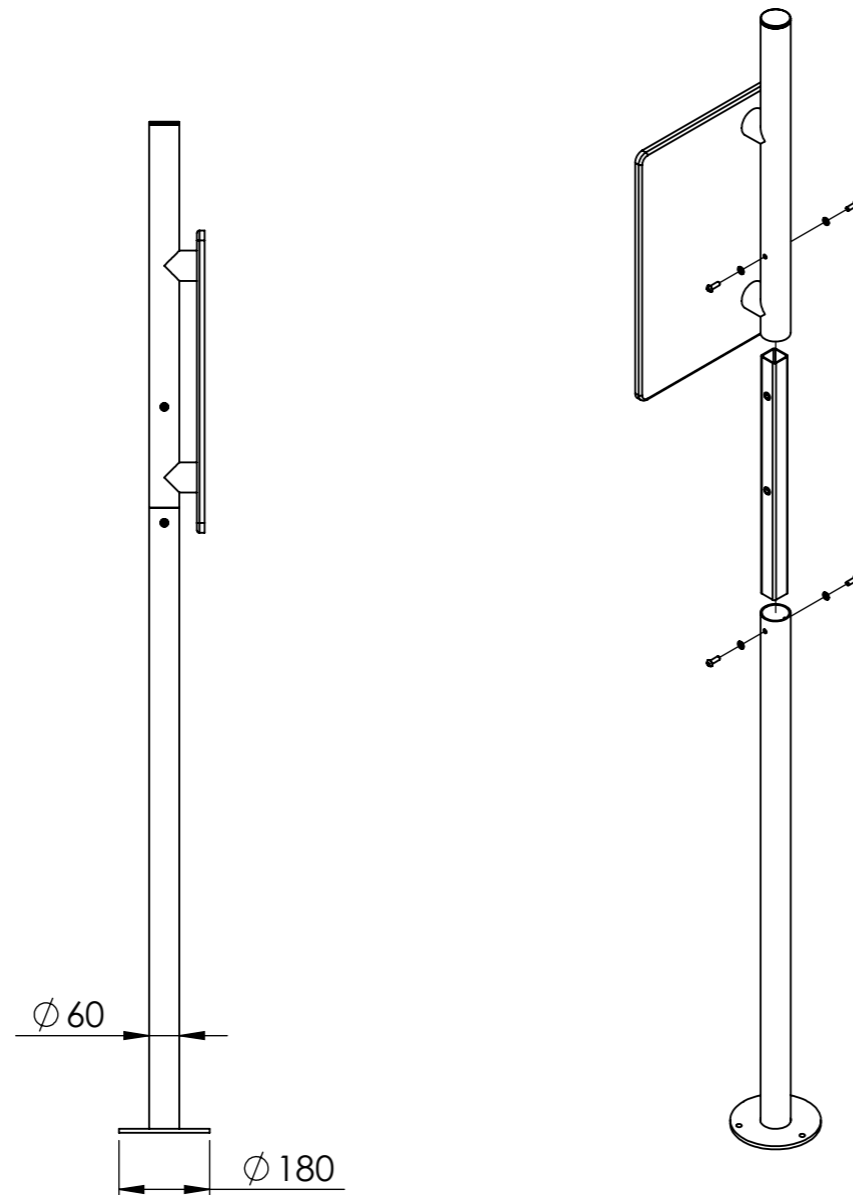
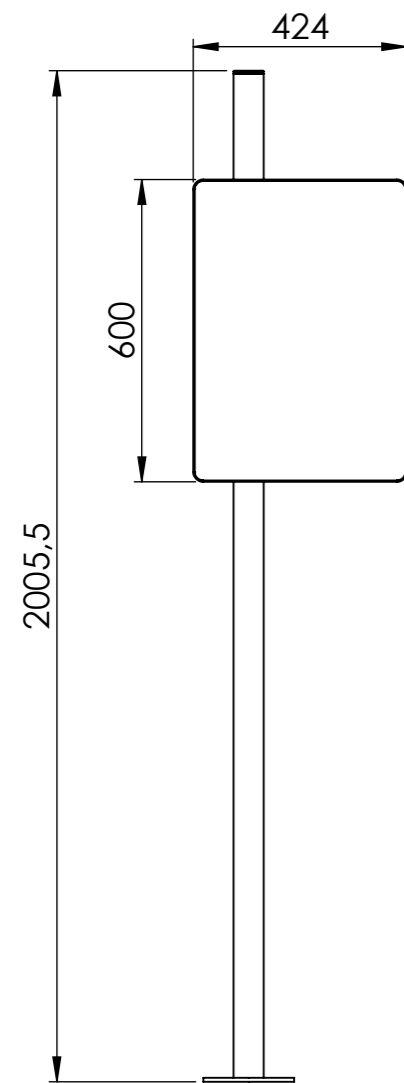

Ö72-10

Kebne Sign

Assembly

The sign is delivered in three parts, a top, a foot and a connecting tube.

The assembly is done with 4 included screws and 4 washers, as shown in the picture.

Kebne Sign

Assembly on ground

Ritad av Joachim Henriksson
Ritad datum 2025-02-10

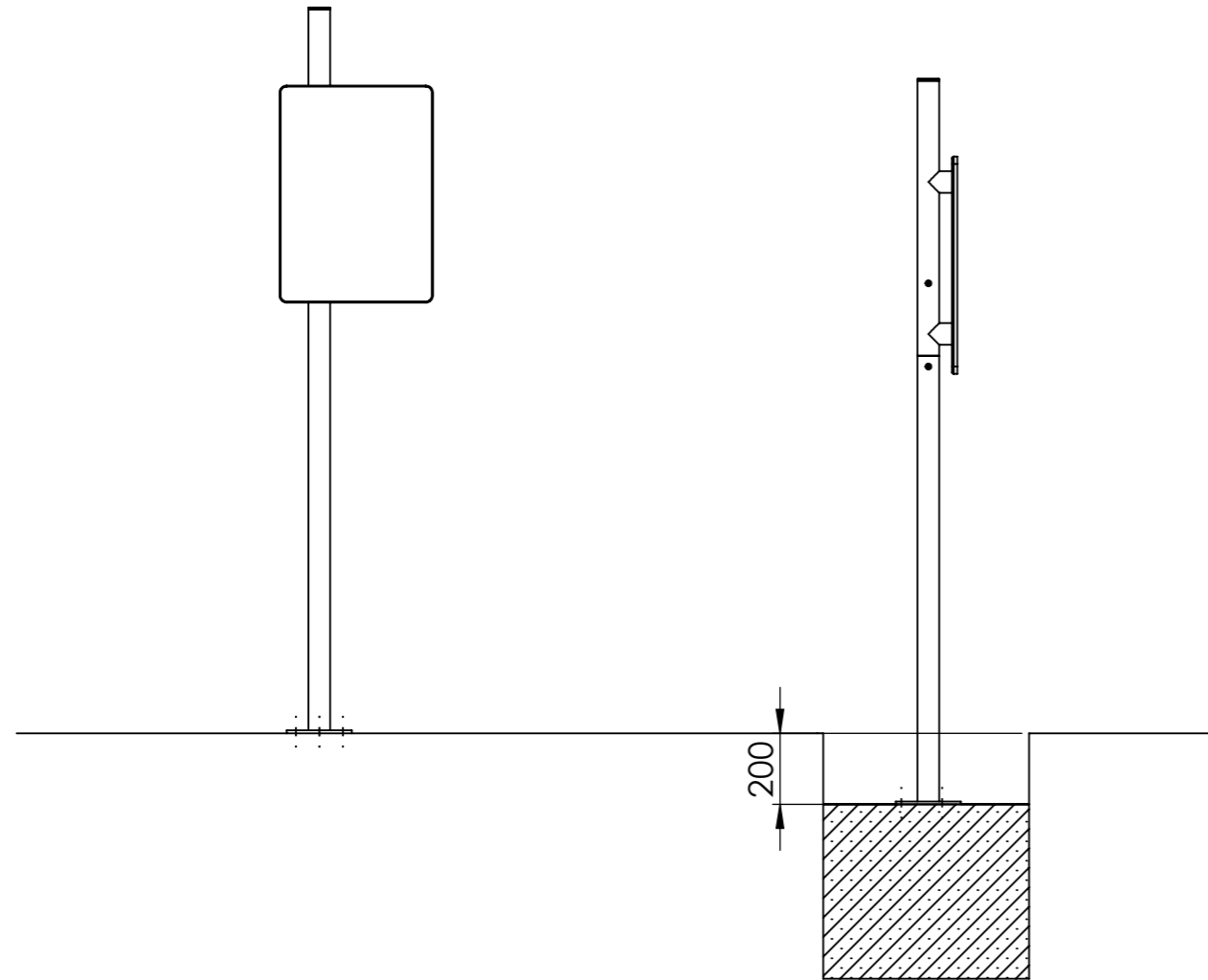

Surface mount

The furniture in the series has perforated footplates for mounting with M10 screws.

Mounting on wooden surfaces

Pre-drill and mount with French wood screws.

Mounting against concrete or stone blocks, etc.

Mount with chemical anchors or expanders as above.

Ground-mounted

When mounting Kebne Sign a little below the ground.

1. Dig to a frost-free depth and base with non-frost-resistant material.

2. Use prefab foundations or cast concrete foundations on site.

3. Drill holes in the foundation and mount with chemical anchors or expanders.

4. Finally, fill in about 200 mm with shock-absorbing substrate. For example, bare soil, gravel or sand.