

Assembly instructions

Ritad av Odin Sollie
Uppdaterad 2023-10-31

Join Terrace furniture

Table of contents

Overview furniture series	s. 2
System description	s. 3
Assembly tables and benches	s. 4
Assembly stools	s. 5
Fastening	s. 6
Refurbish, Dismantle, Recycle	s. 7
<u>Individual product info</u>	
U80-80 Join Planter	s. 8
U80-81 Join Table 900	s. 9
U80-82 Join Bench 650	s. 10
U80-83 Join Stool 650	s. 11
U80-83PP Join Stool perforated 650	s. 12
U80-84 Join Table 780	s. 13
U80-85 Join Bench 480	s. 14
U80-85Bord Join Bech 480 with table	s. 15
U80-86 Join Stool 480	s. 16
U80-86PP Join Stool perforated 480	s. 17
U80-87 Join Tabletop for planter	s. 18

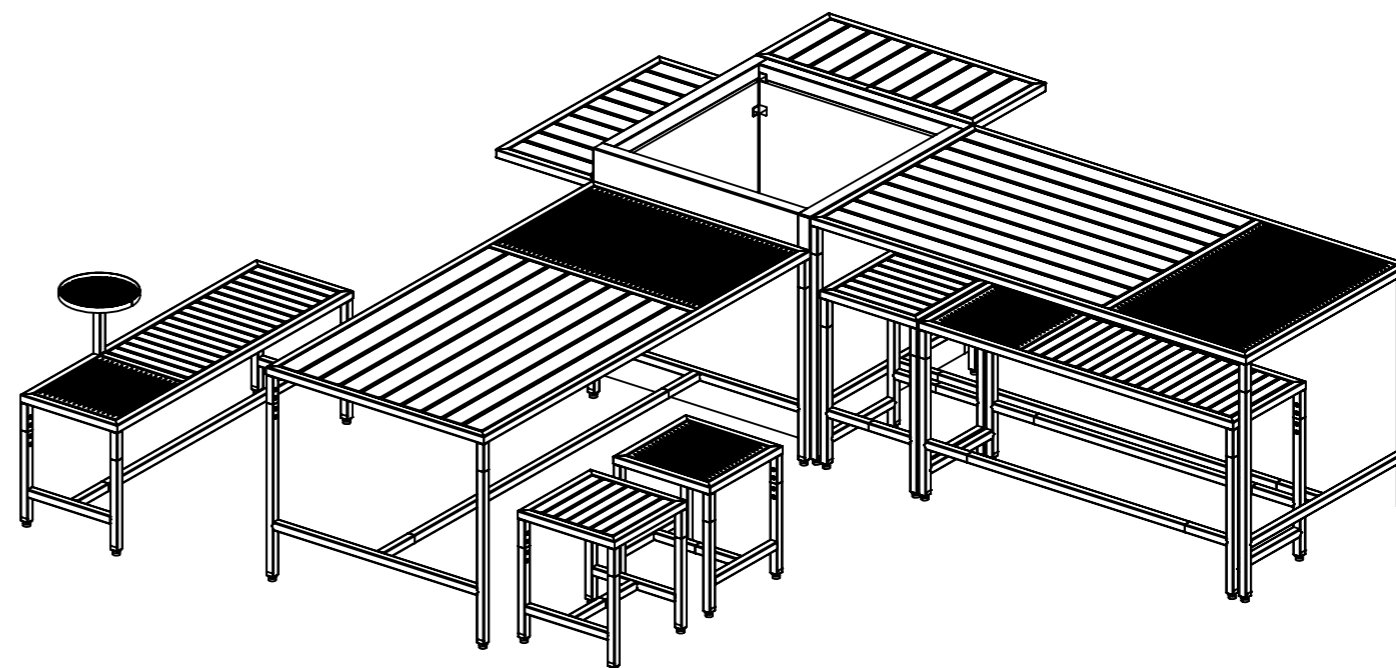

Join Terrace furniture Overview furniture series

Ritad av Odin Sollie
Uppdaterad 2023-10-31

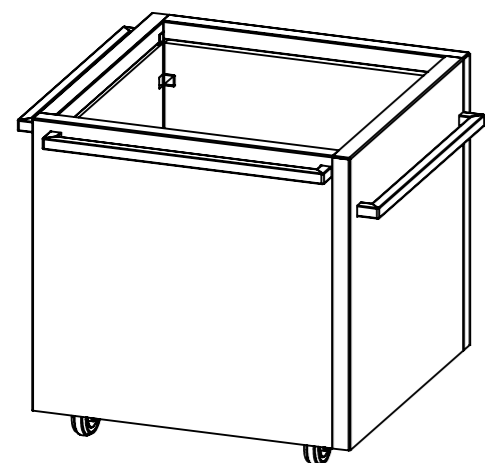

U80-80
Join Planter

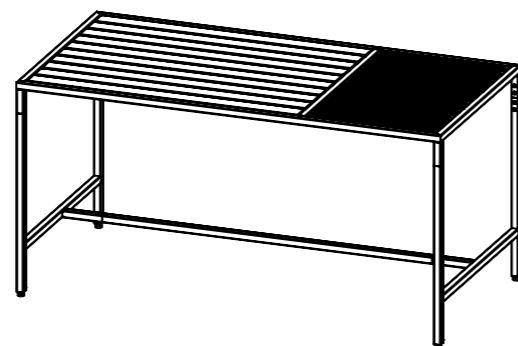

U80-81
Join Table 900

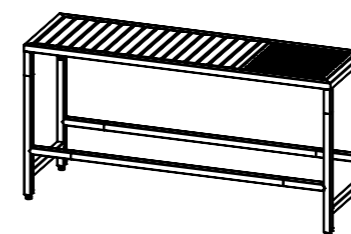

U80-82
Join Bench 650

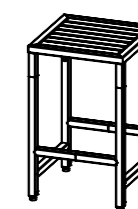

U80-83
Join Stool 650

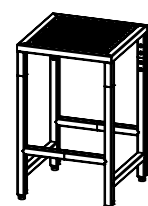

U80-83PP
Join Stool perforated 650

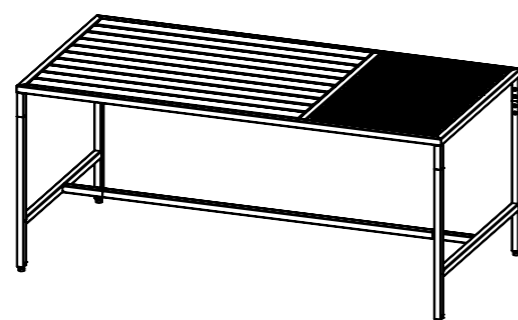

U80-84
Join Table 780

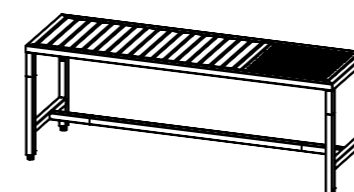

U80-85
Join Bench 480

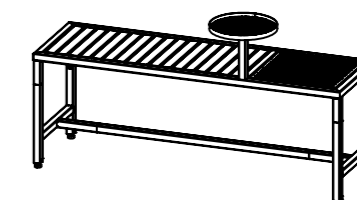

U80-85Bord
Join Bench 480
with table

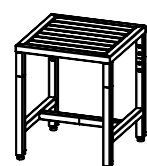

U80-86
Join Stool 480

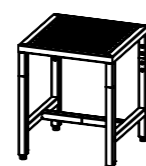

U80-86PP
Join Stool perforated 480

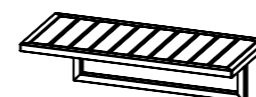

U80-87
Join Tabletop for planter

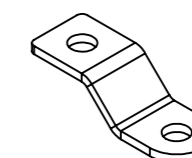

U80-81BESLAG
Fastening bracket 1 pc

Join Terrace furniture System description

Ritad av Odin Sollie
Uppdaterad 2023-10-31

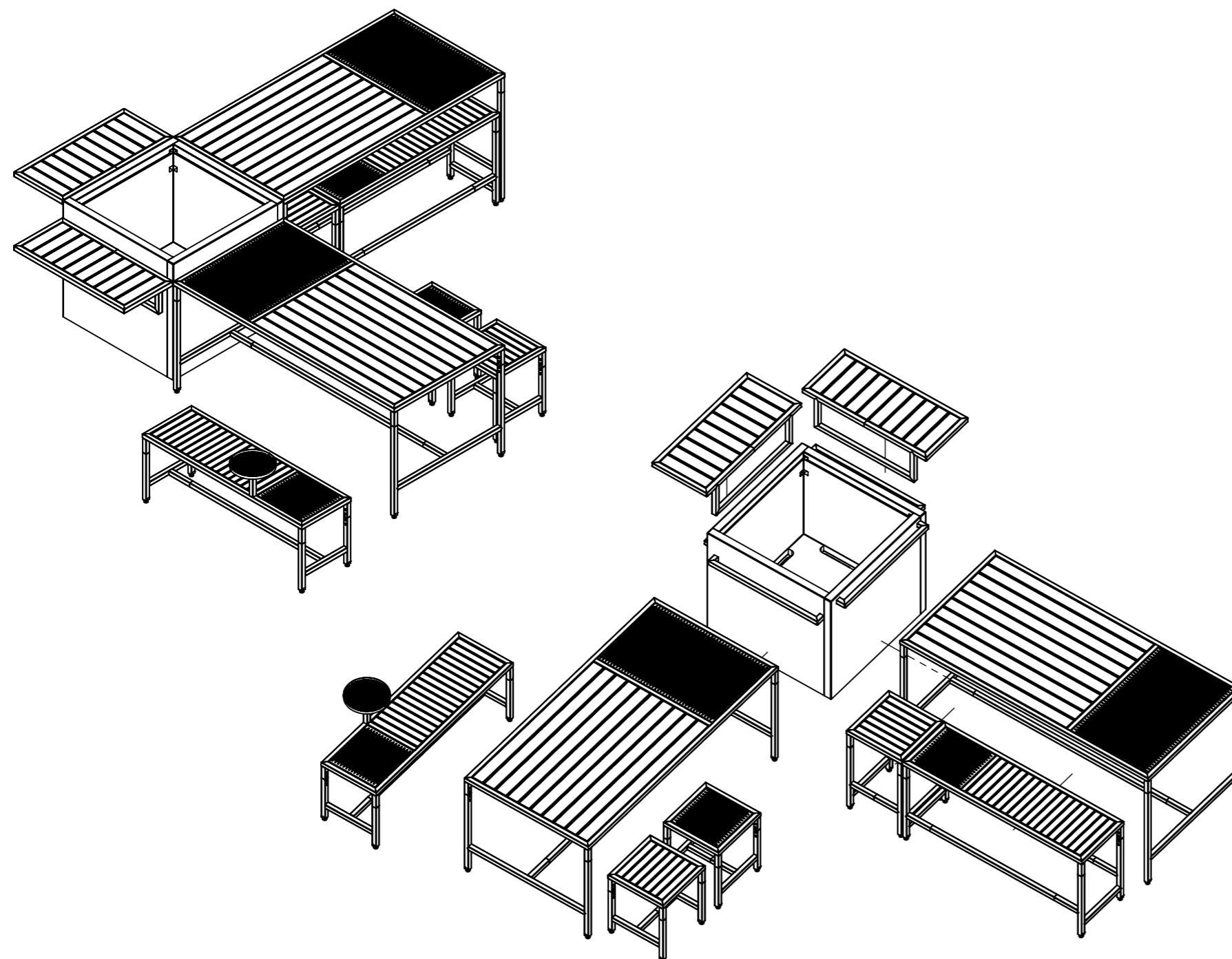

System description

The Join furniture can easily be put together to form coherent furnishings.

This is mainly based on the handles of the planter. These can be used as connectors between the legs of the tables, and also house the planter tabletop.

On the long sides of the tables, there is space for a bench and a stool to be slid in between the table legs beside each other.

Join Terrace furniture

Assembly tables and benches

Ritad av Odin Sollie
Uppdaterad 2023-10-31

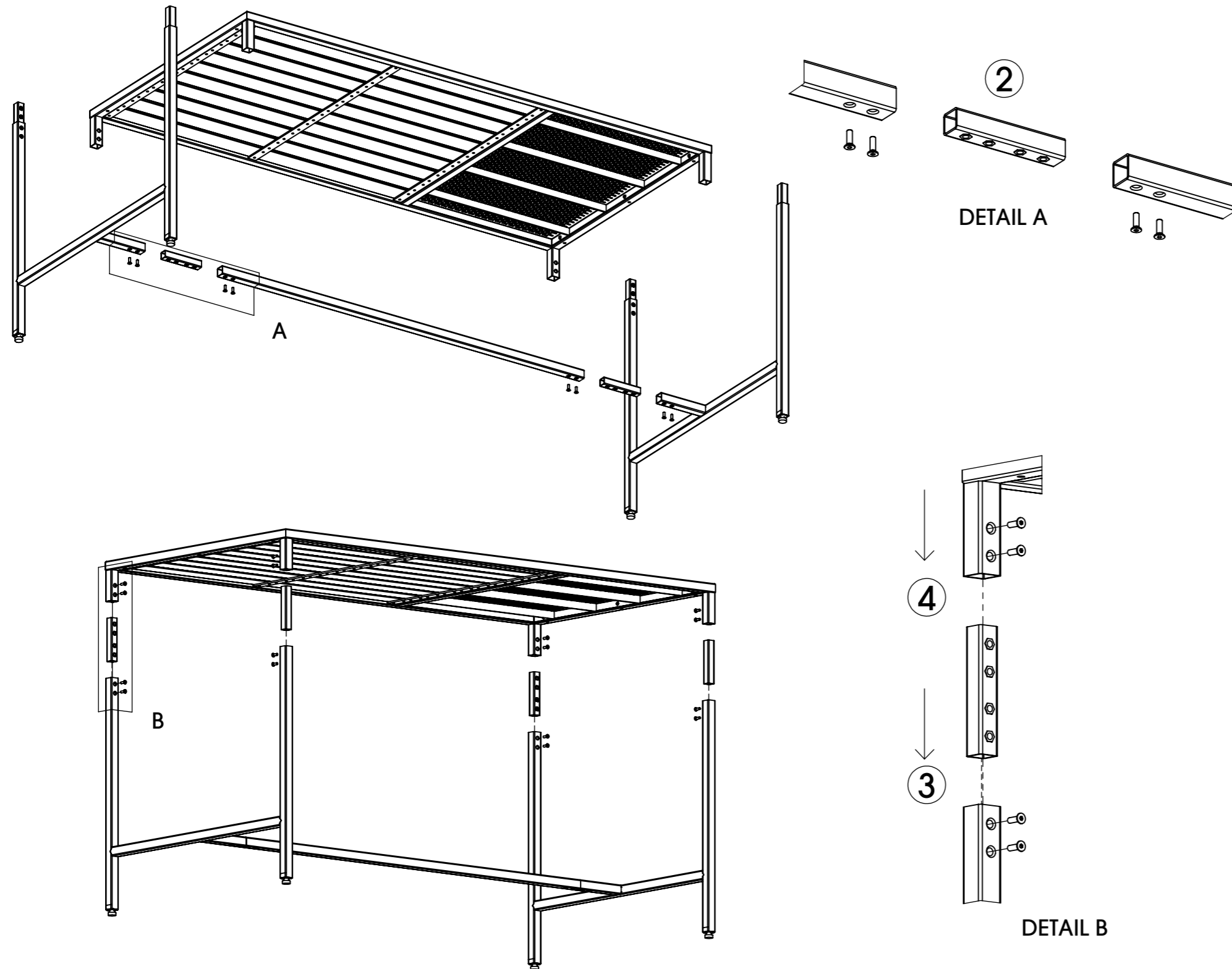

Join's tables and benches are delivered as 4-5 different parts, 6-8 connectors with threaded inserts and 4 screws per connector.

Table and bench tops come with the boards and perforated plates pre-assembled. In addition to the furniture tops, the table and bench come with 2 leg frames and either 1 or 2 crossbars.

Assembly is carried out in the following steps:

- 1)** During the assembly, do not tighten any of the screws too firmly. Just thread them to connect all the parts of the furniture and then tighten all the screws simultaneously.
- 2)** Install one connector in each end of the crossbars. Then, connect the 2 leg frames via the crossbars and connectors.
- 3)** With the leg frames standing on its own, mount the remaining 4 connectors in the empty tube ends.
- 4)** The top is added by sliding its four tubes over the connectors and securing them with the remaining screws.
- 5)** Now, gradually tighten all the screws simultaneously, ensuring the fit is as tight as possible and that any gaps in the tube joints are minimized.

Join Terrace furniture Assembly stools

Ritad av Odin Sollie
Uppdaterad 2023-10-31

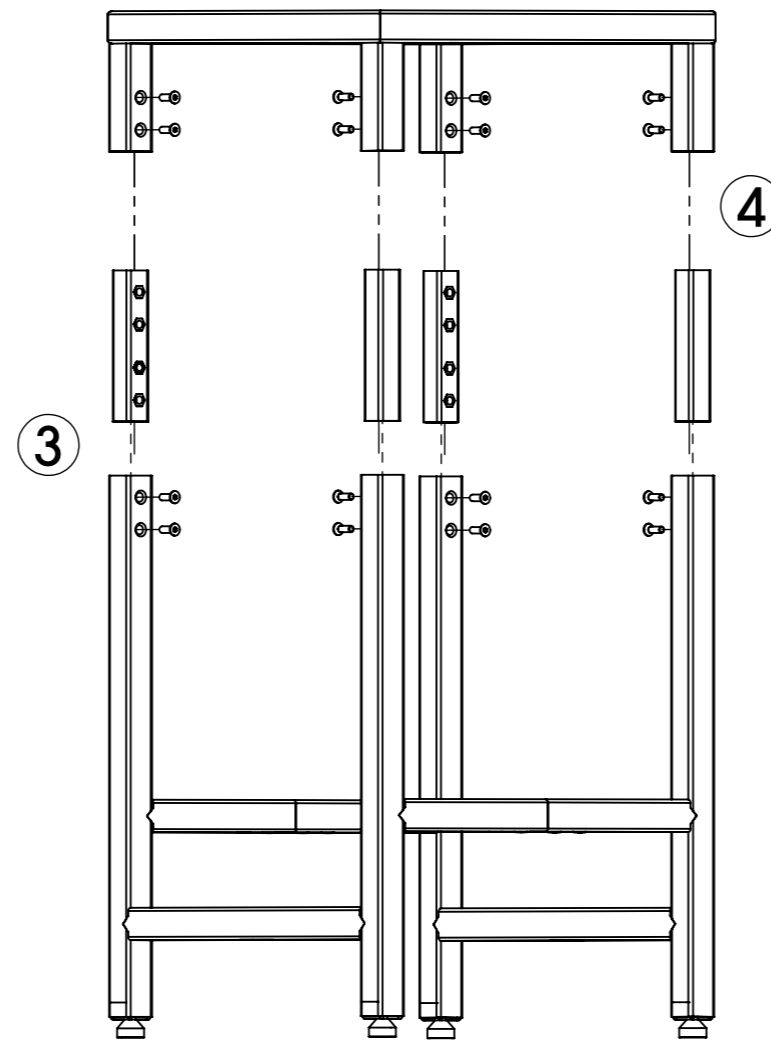
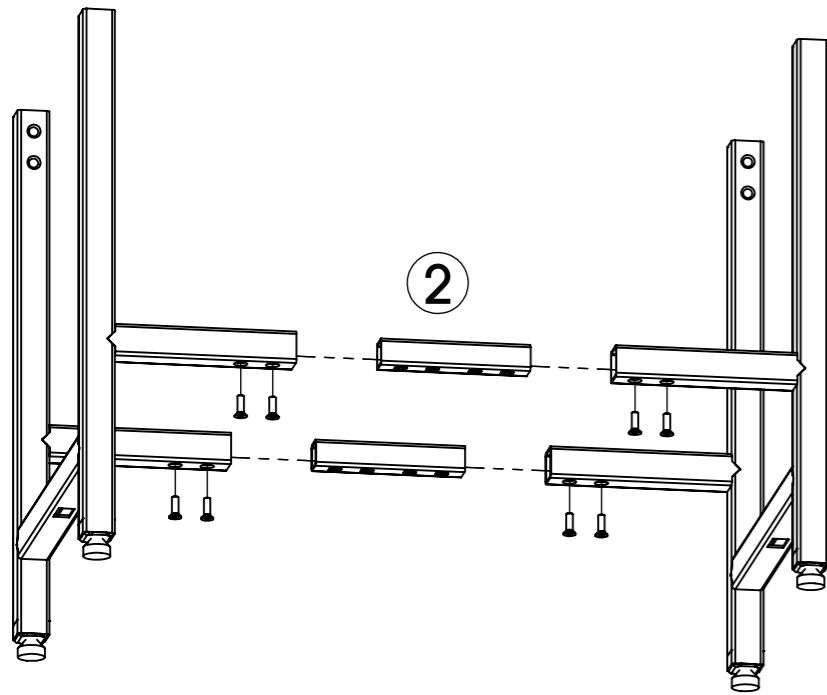

Joins stools are delivered in 3 different parts, with 5-6 connectors with threaded inserts and 4 screws per connectors.

Stool tops come with boards or perforated plates pre-assembled. In addition to the tops, the stools come with 2 leg frames.

Assembly is carried out in the following steps:

- 1)** During the assembly, do not tighten any of the screws too firmly. Just thread them to connect all the parts of the furniture and then tighten all the screws simultaneously.
- 2)** Connect the leg frames to each other using 1 or 2 connectors depending on the stool model.
- 3)** With the leg frames standing on their own, mount the remaining 4 connectors in the empty tube ends.
- 4)** The top is added by sliding its 4 tubes over the telescopic tubes and securing them with the remaining screws.
- 5)** Now, gradually tighten all the screws simultaneously, ensuring the fit is as tight as possible and that any gaps in the tube joints are minimized.

Join Terrace furniture Fastening

Ritad av Odin Sollie
Uppdaterad 2023-10-31

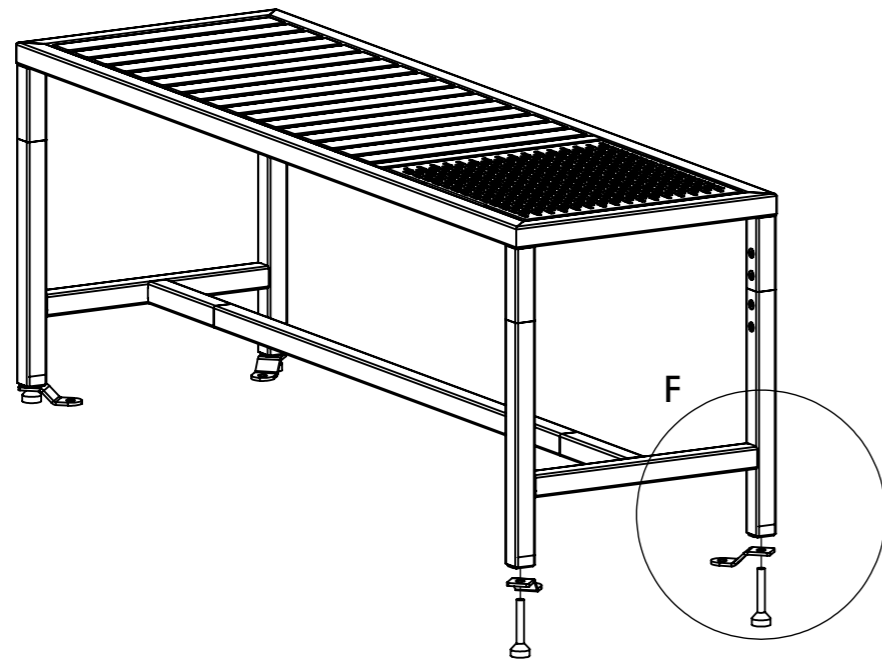

DETAIL F

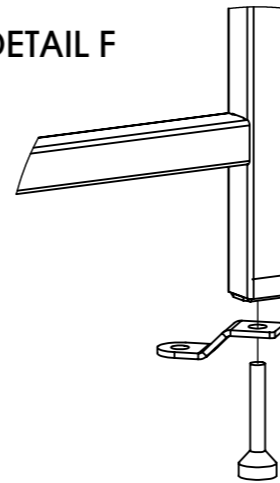

Join's tables, benches, and stools can all be fastened to the floor if necessary. To do so, fastening brackets must be purchased and combined with the adjustable feet.

However, the furniture does not need to be secured to stand firmly, so for supervised areas, it is recommended to leave the furniture freestanding in favor of adaptable arrangements.

When placing an order, please specify:
U80-81BESLAG - Fastening Bracket, 1 pc

For one piece of furniture, we recommend 4 brackets or 2 brackets diagonally.

Assembly is carried out as follows:
Completely unscrew the adjustable feet from the legs, slide the fastening brackets over the threaded rods, and screw the feet back on. The furniture can be bolted to the surface with **M10 bolts**.

Since the brackets are loose, the resulting hole pattern is not very precise. Therefore, it is recommended to pre-drill directly through the holes of the brackets, followed by fastening with bolts. For easier access with tools, the brackets can be rotated **45°** under the furniture so that various braces do not obstruct.

Fastening on wooden surfaces:

Pre-drill and mount with 10mm french wood screws.

Fastening on cobblestones or pavement slabs:

Place prefab concrete foundations under the stone or slabs. There must be no sand between the slabs and the concrete or else the slabs might crack. Drill the slab for expansion or chemical anchors.

Fastening to concrete or stone blocks, etc.:

Mount with chemical anchors or expansion anchors as described above. Assembly with expansion anchors provides a removable fastening.

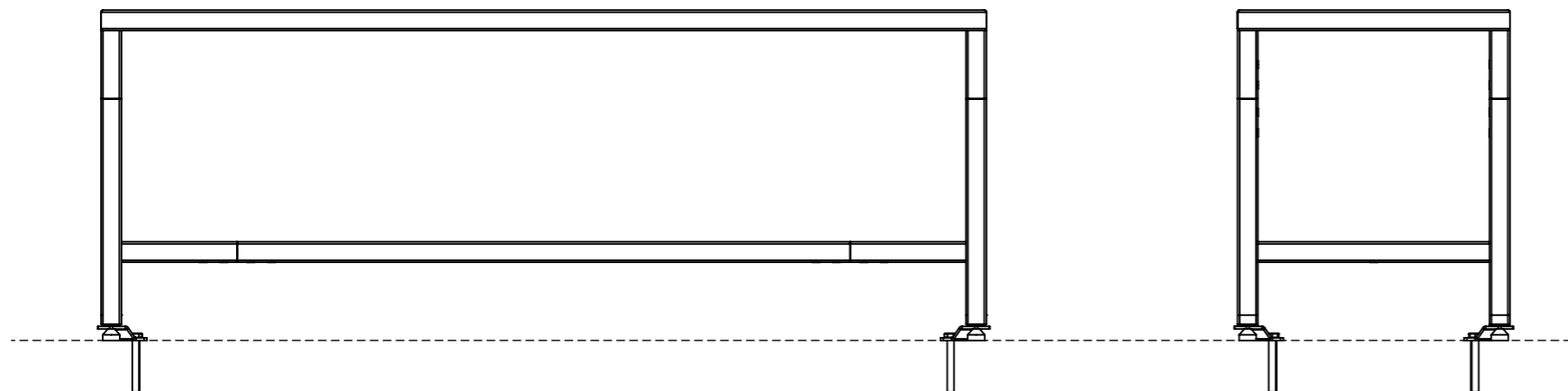

Join Terrace furniture Dissassembly

Ritad av Odin Sollie
Uppdaterad 2023-10-31

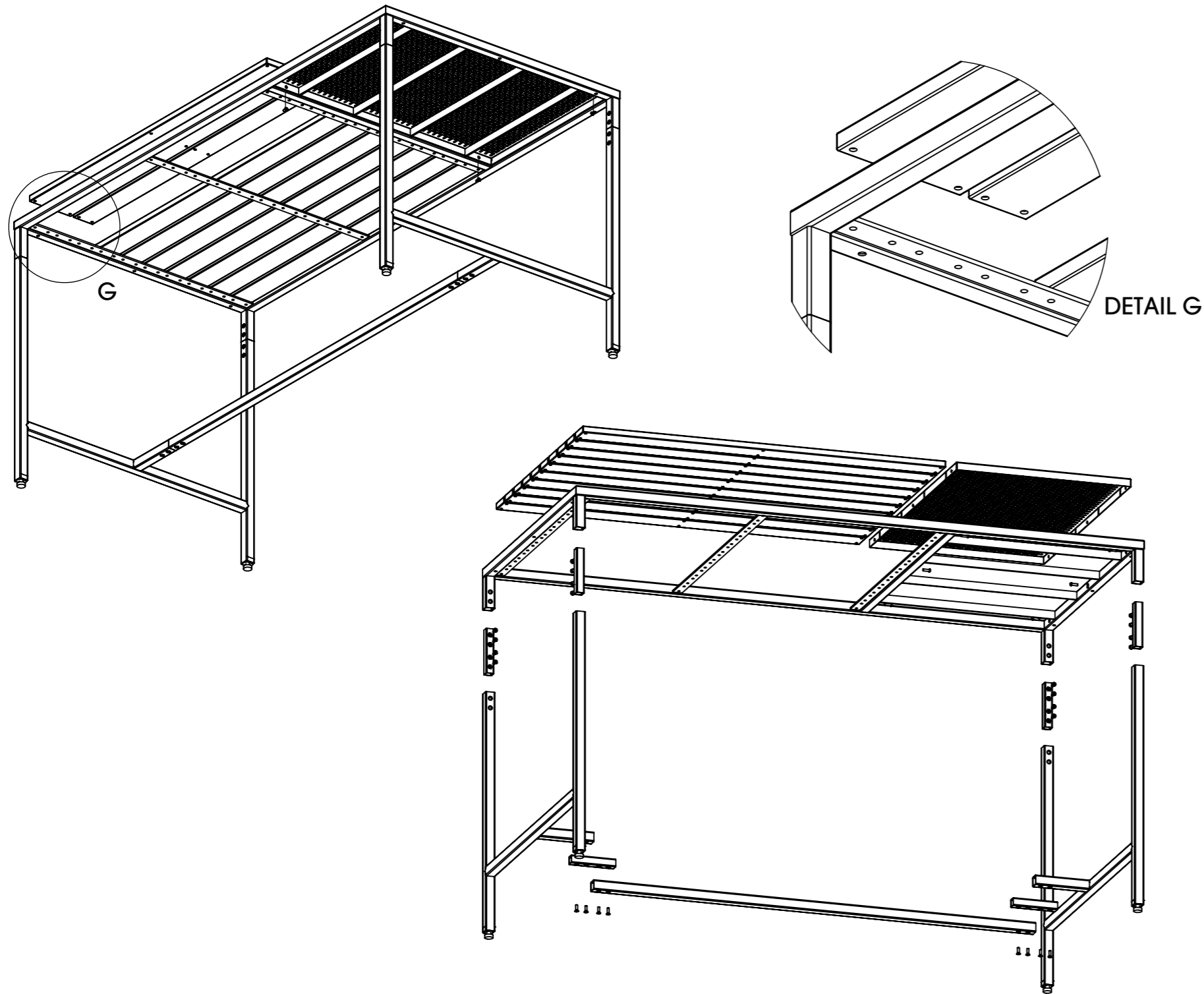

Disassembly

For replacement or repair of the boards, there is no need to disassemble the furniture. All of the wooden screws of the boards can be easily accessed from under the furniture and can be unscrewed independently of each other or the other parts of the furniture.

For larger repairs or recycling of the furniture, it is advisable to disassemble them into the same parts as they came. Unscrew all the screws at the joints and take the furniture apart. They can then be sent back to the supplier for repair or to the appropriate metal recycling facility in a compact manner.

Join Terrace furniture

Join Planter

Ritad av Odin Sollie
Uppdaterad 2023-10-31

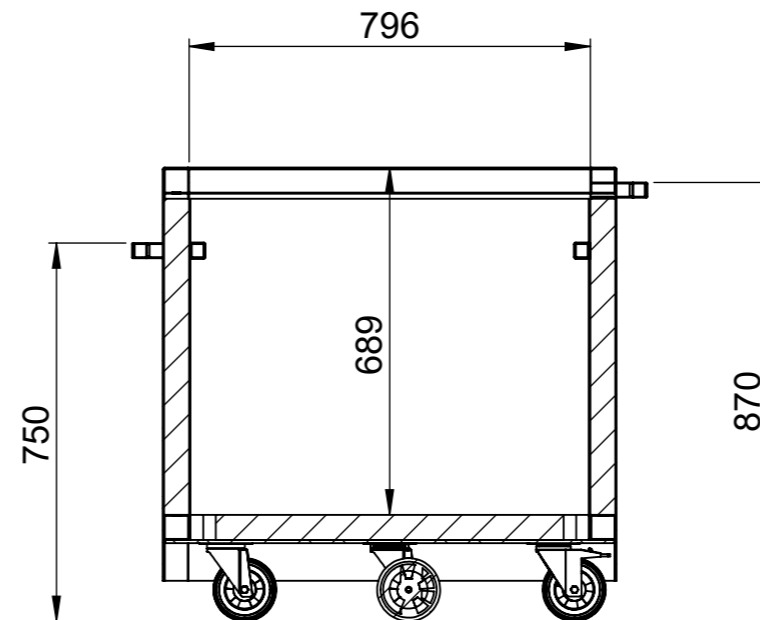
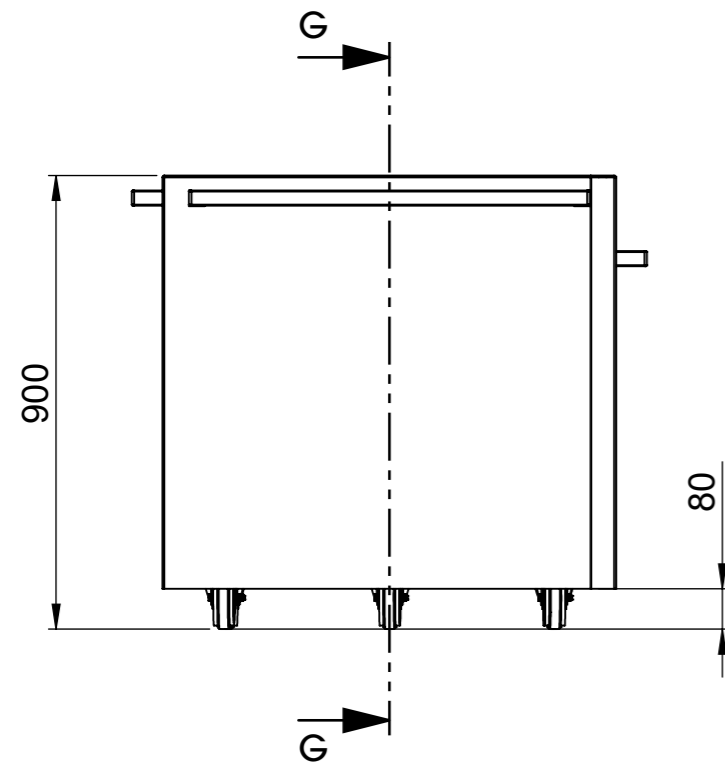

SECTION G-G
SCALE 1 : 15

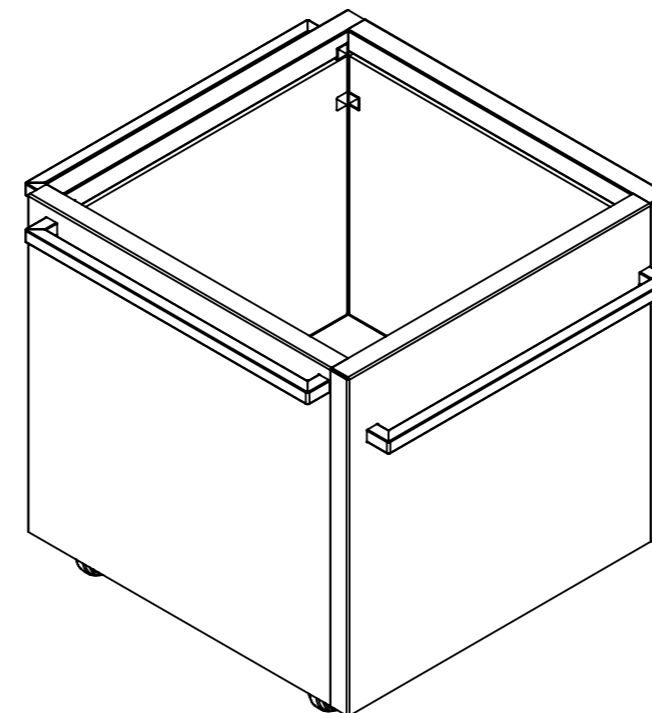
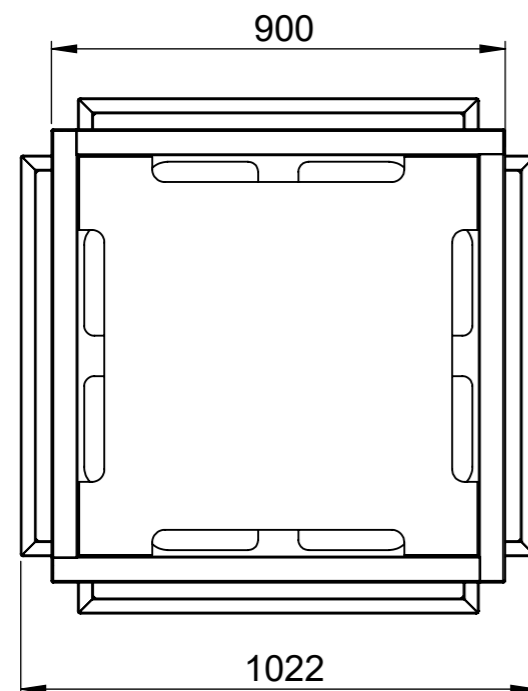

U80-80 Join Planter

Weight: 60 kg

Comes fully assembled with insulation plates and 5 wheels, including 2 locking wheels.
Construction material: Aluminum

When planting, it is recommended to use some form of fabric, such as geotextile. For indoor use, the fabric should be waterproof to retain liquid, while for outdoor planting, the fabric should be drained. The bottom of the box is equipped with drainage.

The planter has handles on all four sides at two different heights. The attachable tabletop can be freely placed on either of the handles. The heights of the handles correspond to the two different table heights. The handles are also used for guidance between the table legs when configuring linked furnishings.

Join Terrace furniture

Join Table 900

Ritad av Odin Sollie
Uppdaterad 2023-10-31

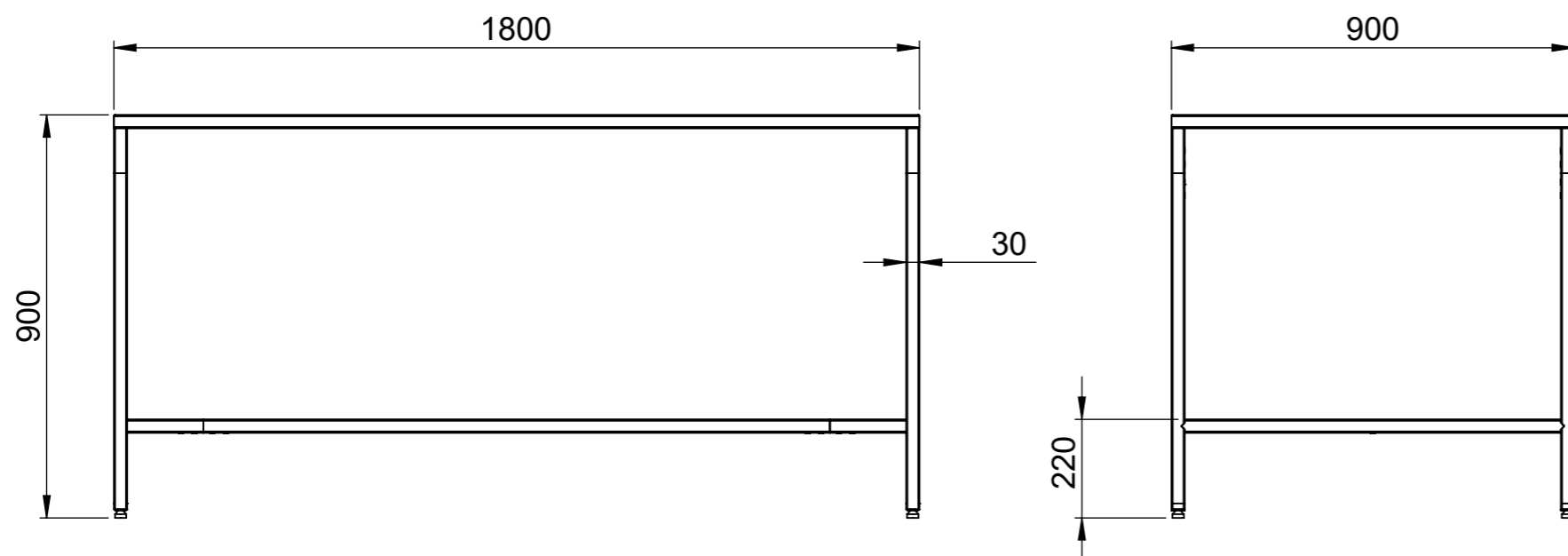

U80-81 Join Table 900

Including adjustable feet, 6 connectors,
and 24 countersunk M6-bolts.
Delivered disassembled. **Weight 44 kg**

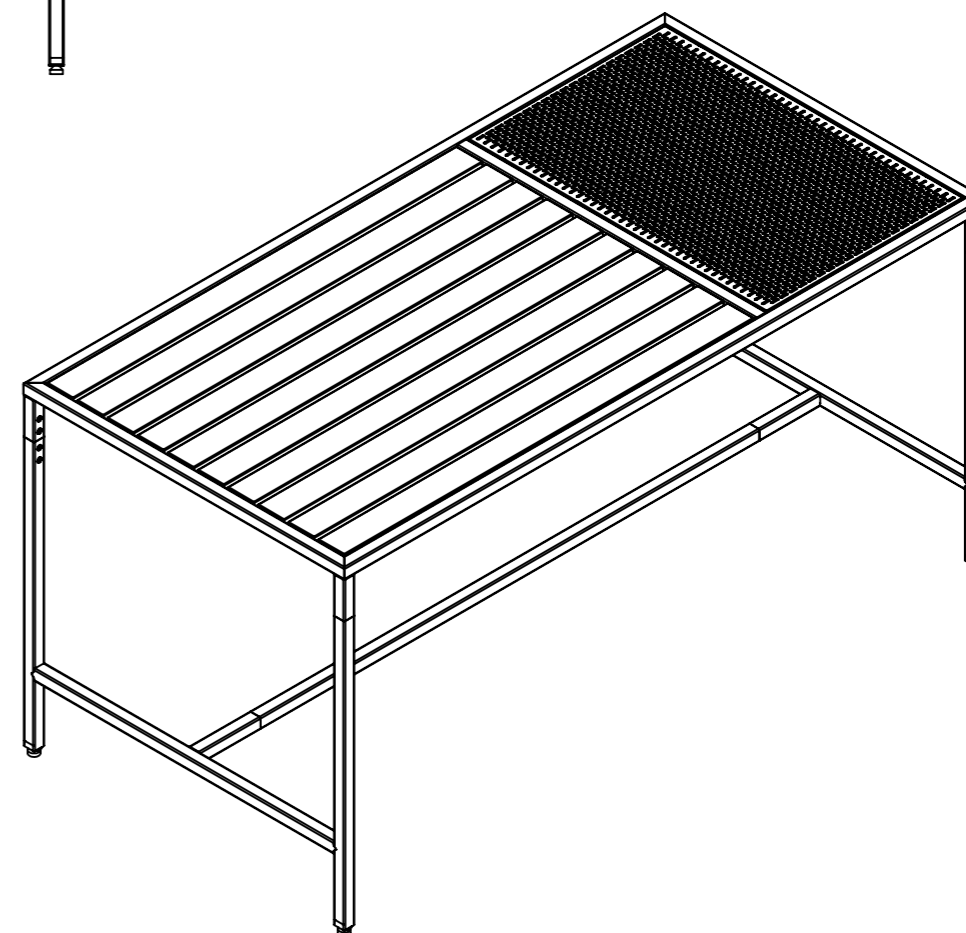
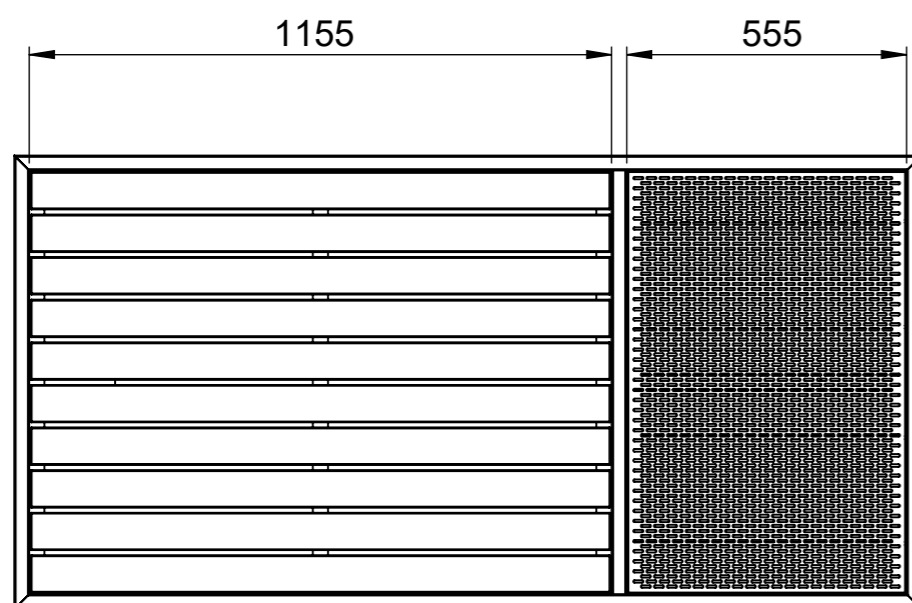

Join Terrace furniture

Join Bench 650

Ritad av Odin Sollie
Uppdaterad 2023-10-31

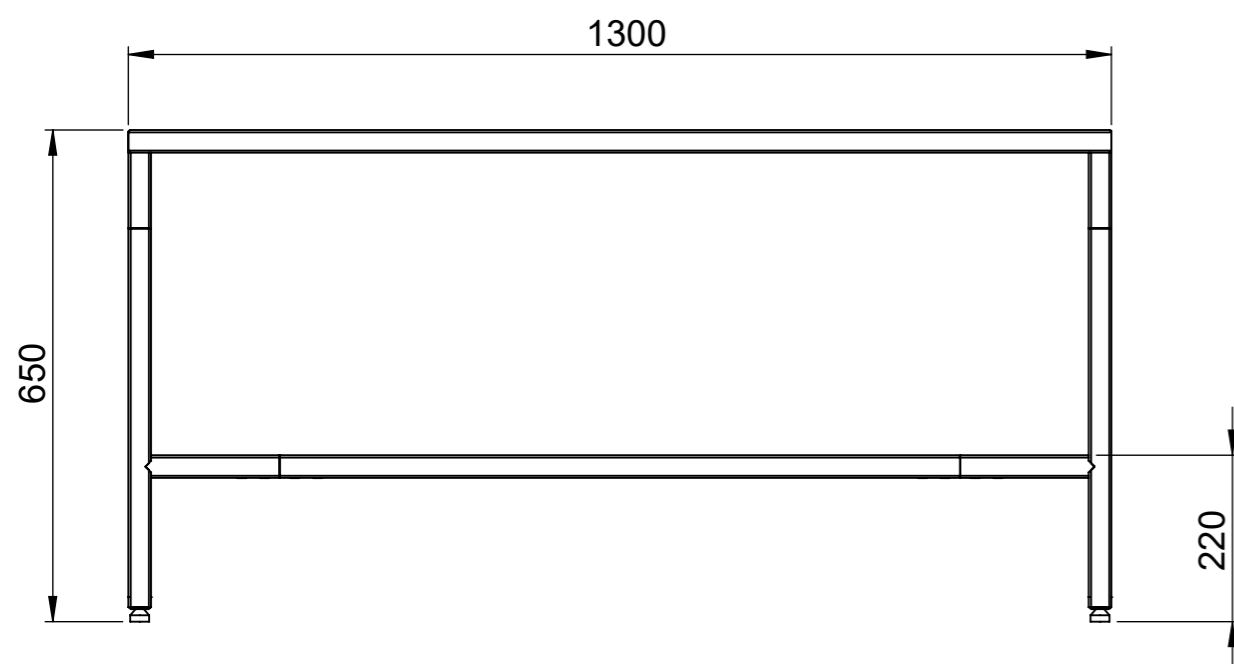

U80-82 Join Bench 650

Including adjustable feet, 8 connectors,
and 32 countersunk M6-screws.
Comes disassembled. **Weight 27 kg**

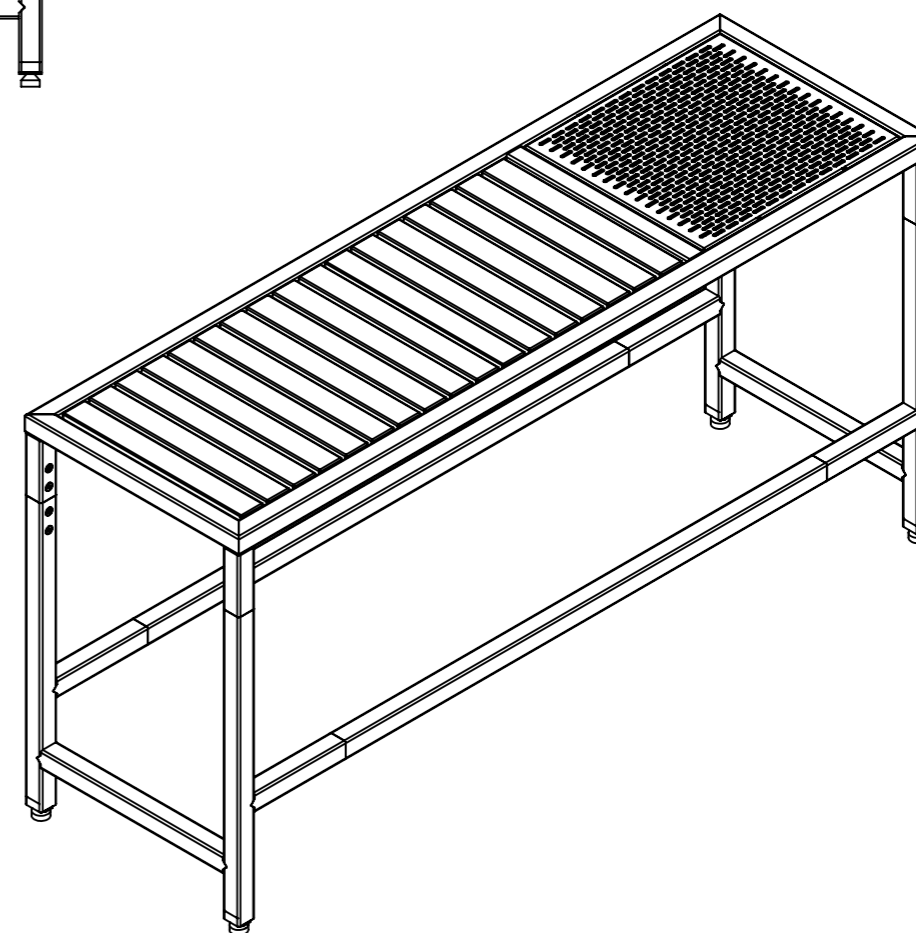
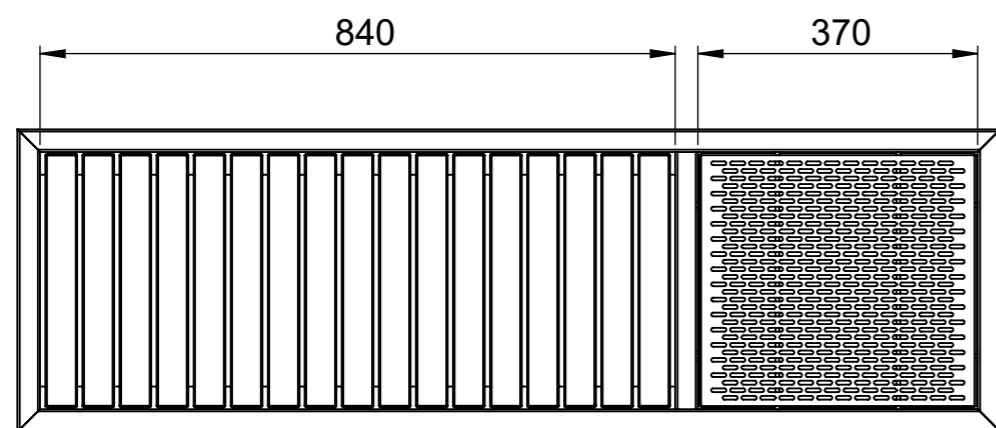

Join Terrace furniture

Join Stool 650

Ritad av Odin Sollie
Uppdaterad 2023-10-31

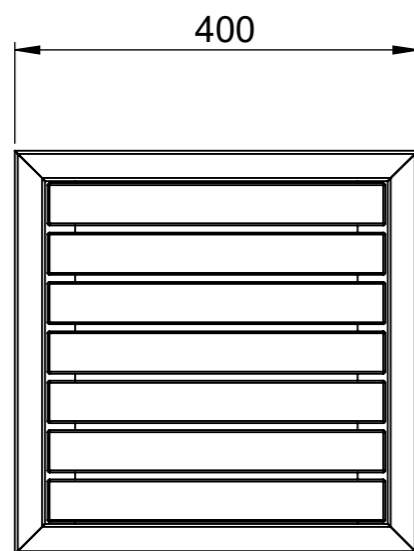
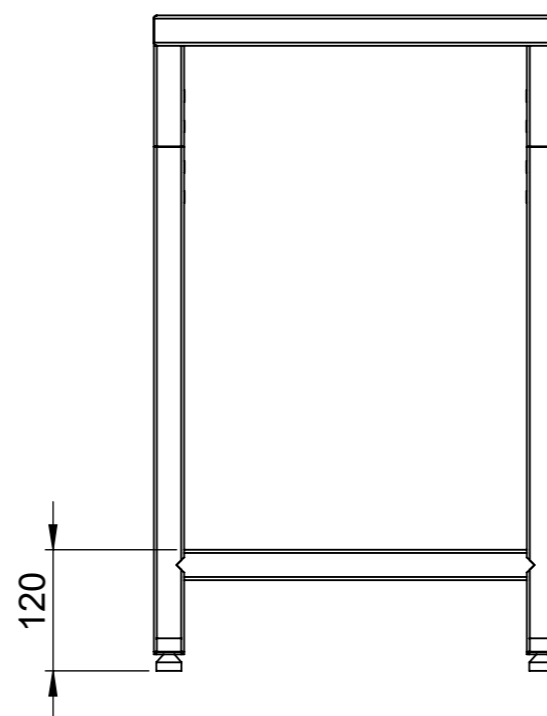
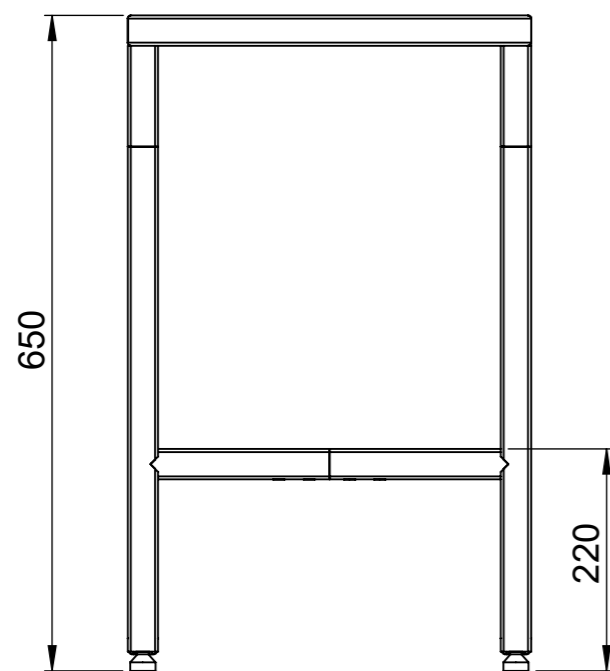

U80-83 Join Stool 650

Including adjustable feet, 6 connectors,
and 24 countersunk M6-screws.
Comes disassembled. **Weight 13,5 kg**

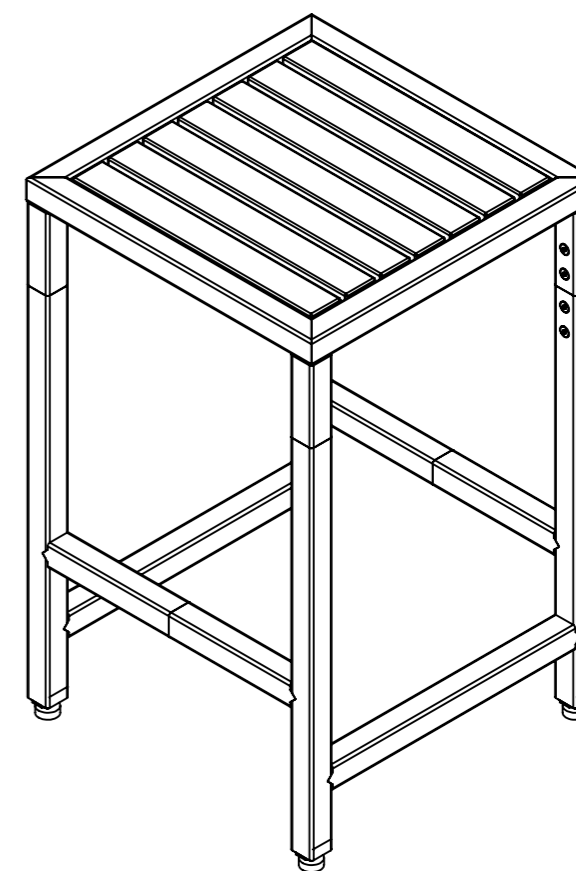

Join Terrace furniture

Join Stool perforated 650

Ritad av Odin Sollie
Uppdaterad 2023-10-31

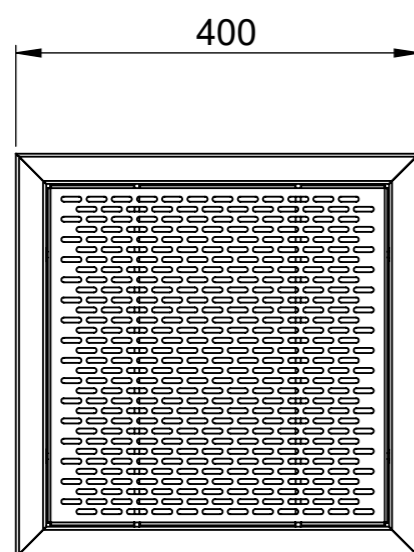
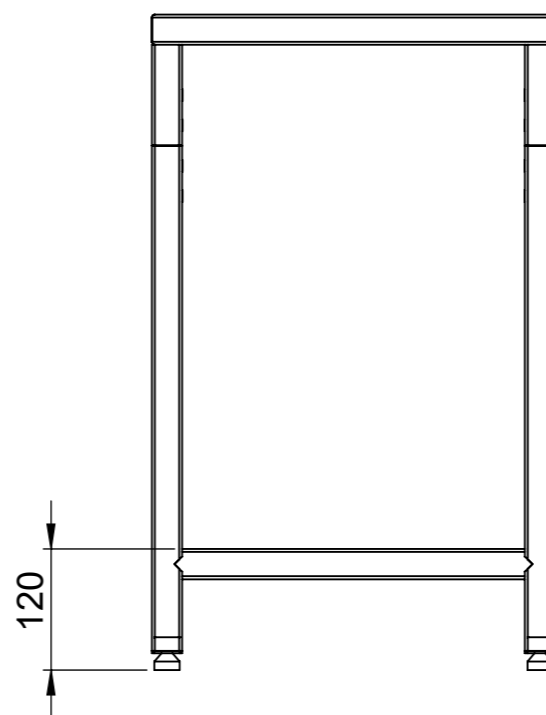
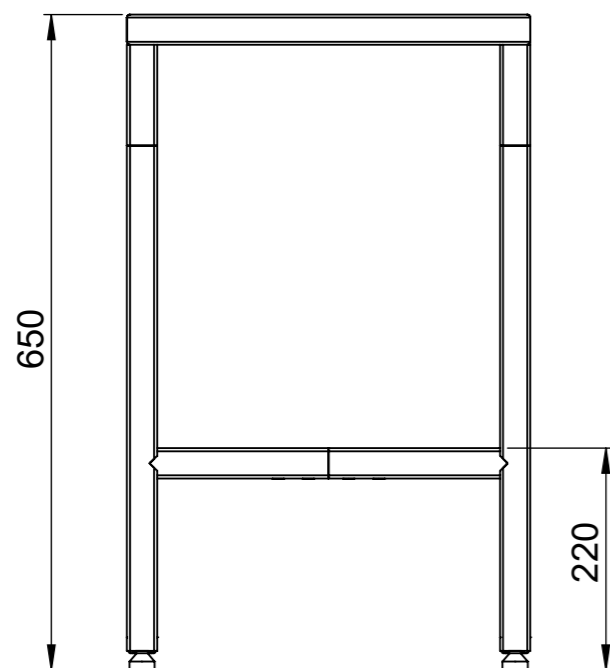

U80-83PP Join Stool perforated 650

Including adjustable feet, 6 connectors,
and 24 countersunk M6-screws.
Comes disassembled. **Weight 13 kg**

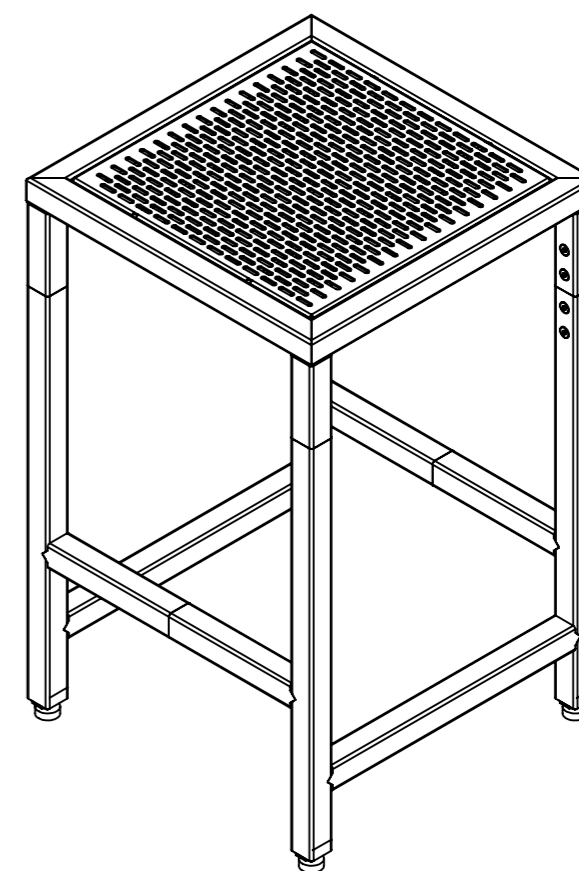

Join Terrace furniture

Join Table 780

Ritad av Odin Sollie
Uppdaterad 2023-10-31

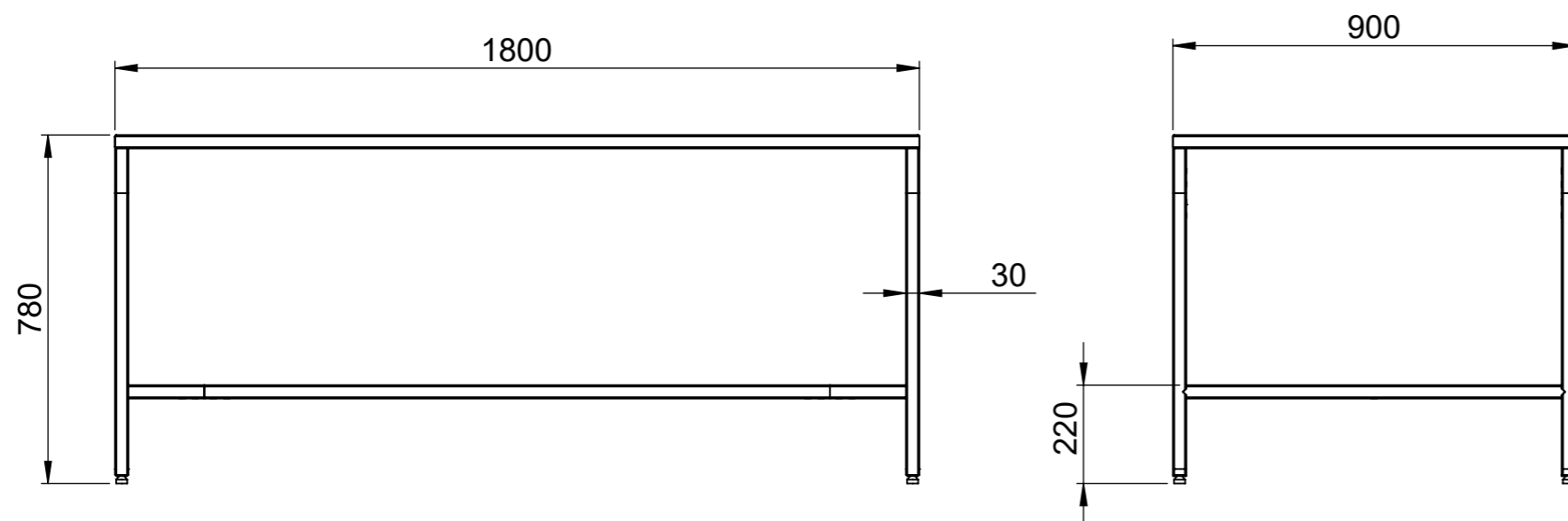

U80-84 Join Table 780

Including adjustable feet, 6 connectors,
and 24 countersunk M6-screws.
Comes disassembled. **Weight 43 kg**

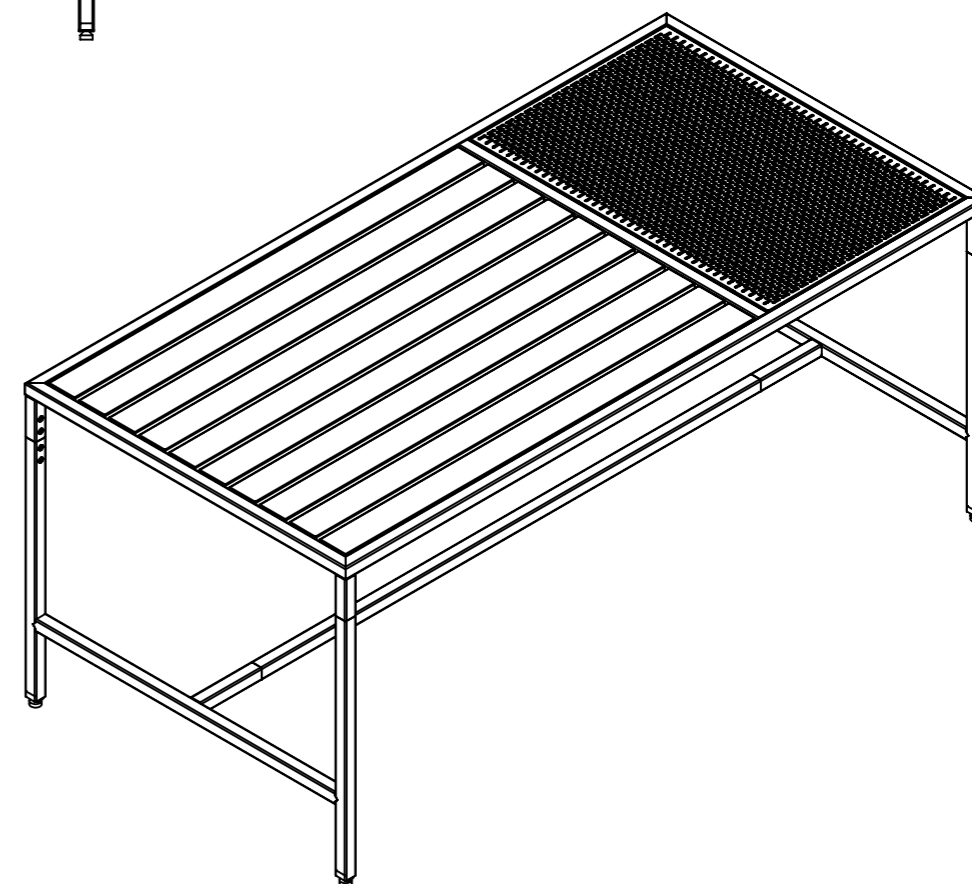
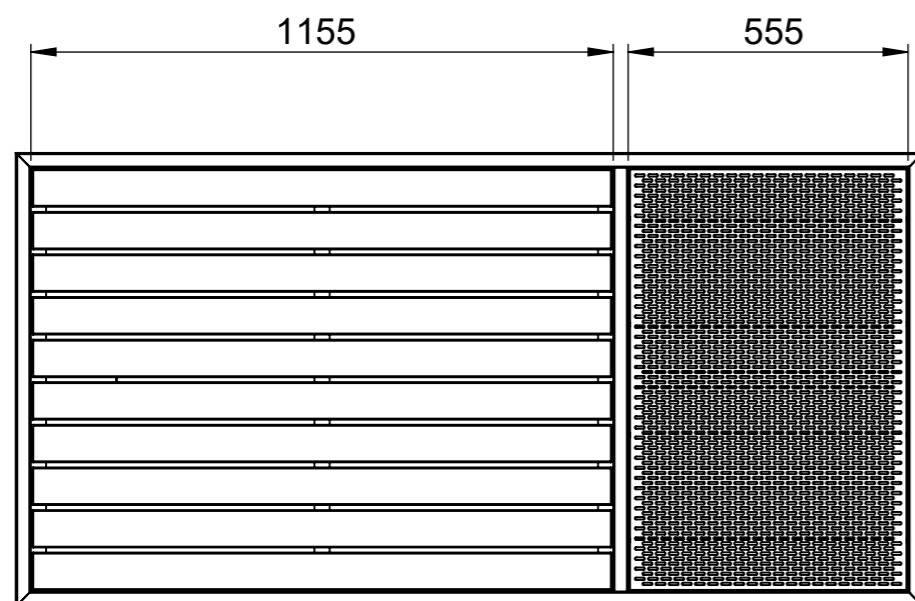

Join Terrace furniture

Join Bench 480

Ritad av Odin Sollie
Uppdaterad 2023-10-31

U80-85 Join Bänk 480

Including adjustable feet, 6 connectors,
and 24 countersunk M6-screws.
Comes disassembled. **Weight 23 kg**

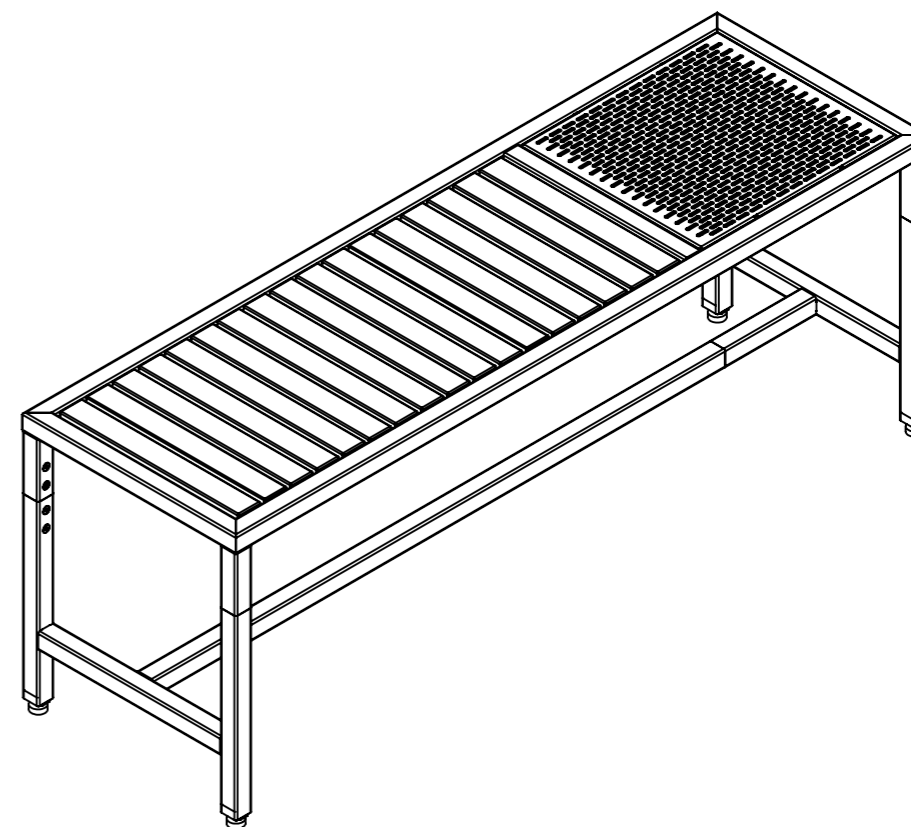
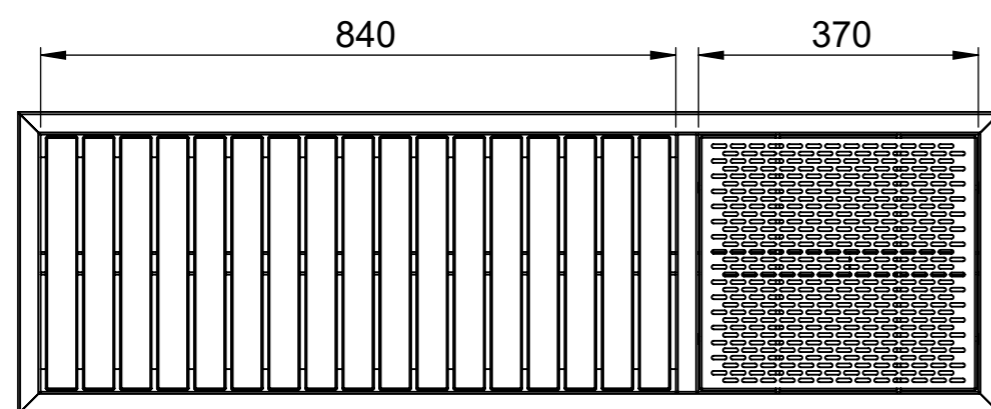
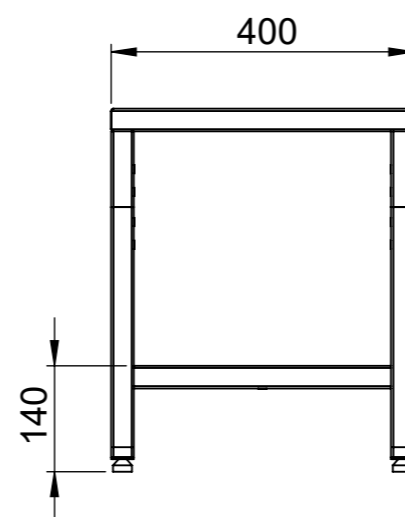
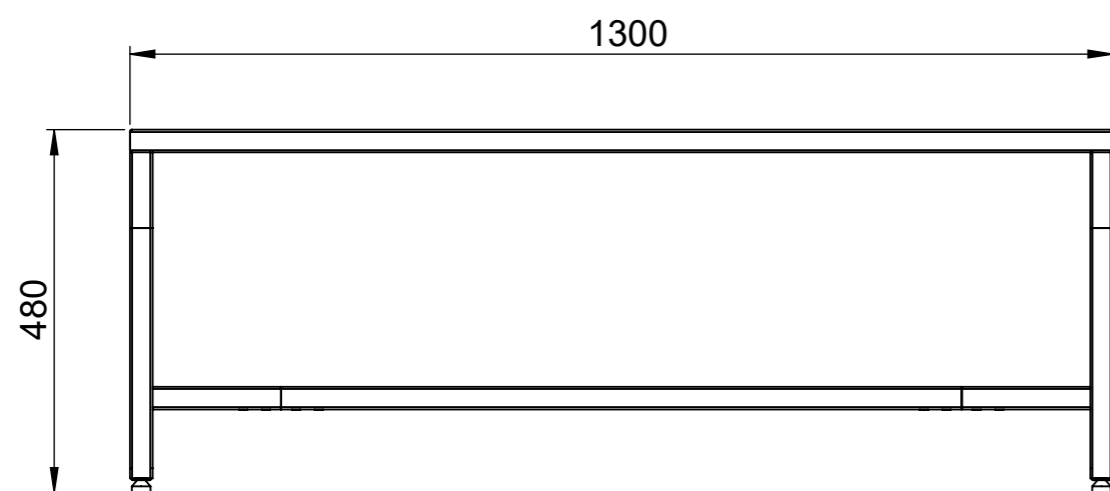

Join Terrace furniture

Join Bench 480 w table

Ritad av Odin Sollie
Uppdaterad 2023-10-31

U80-85PP Join Bench 480 with table

Including adjustable feet, 6 connectors,
and 24 countersunk M6-screws.
Comes disassembled. **Weight 24,5 kg**

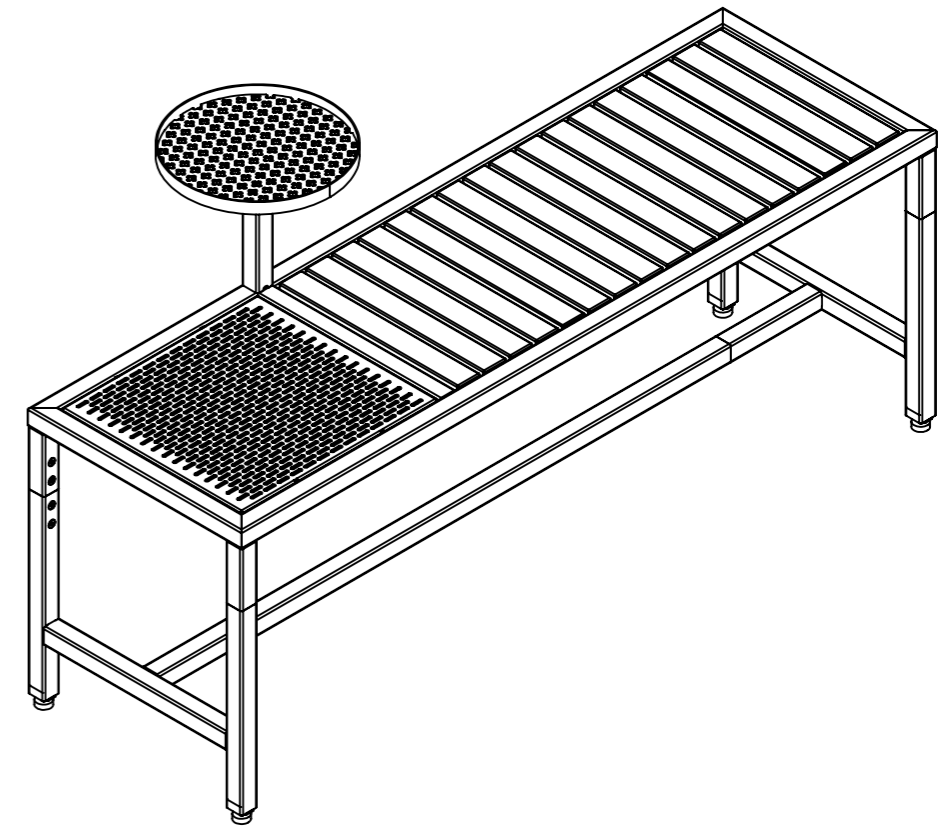
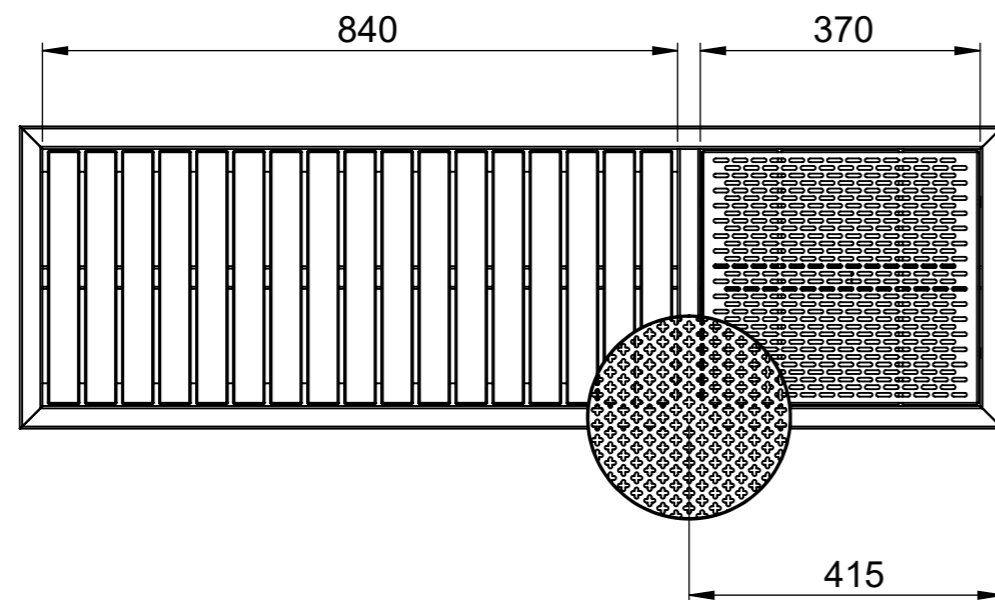
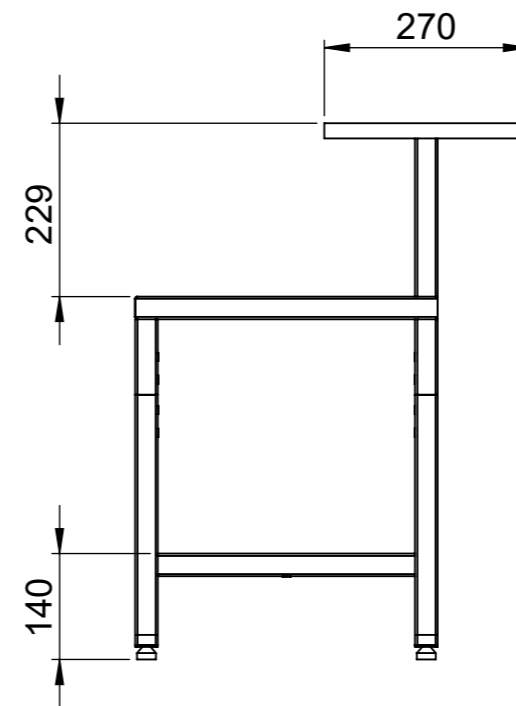
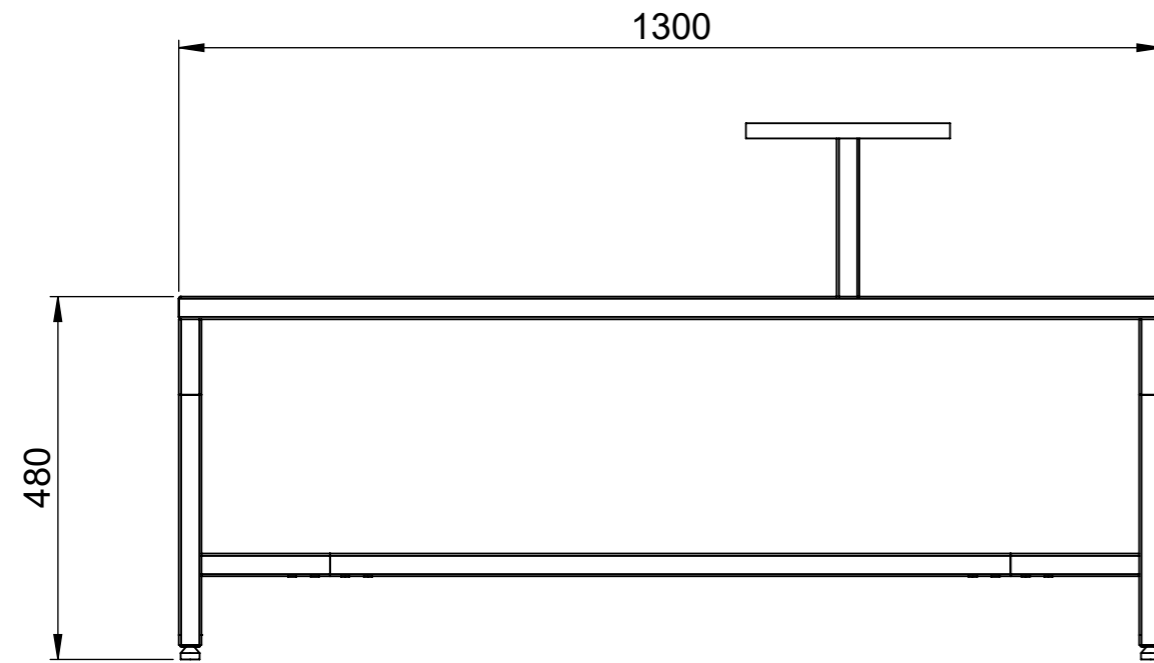

Join Terrace furniture

Join Stool 480

Ritad av Odin Sollie
Uppdaterad 2023-10-31

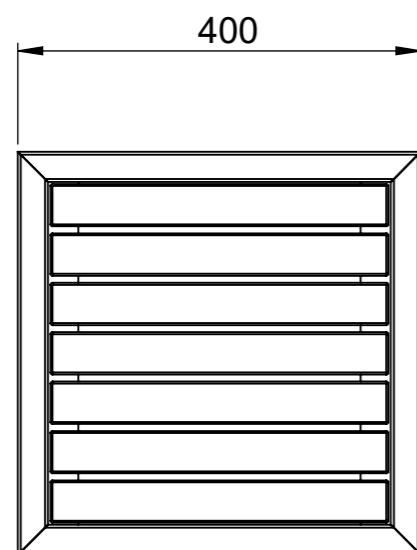
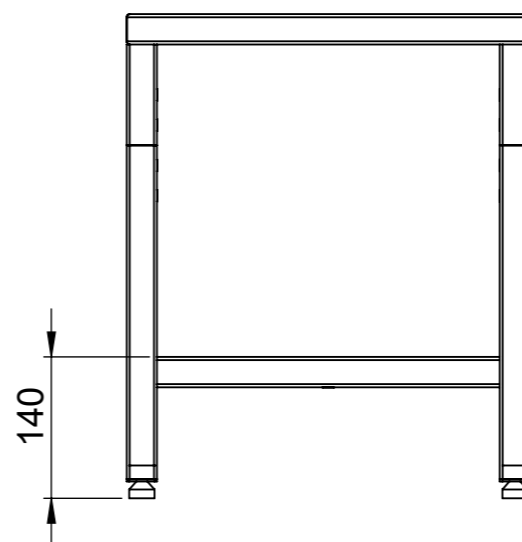
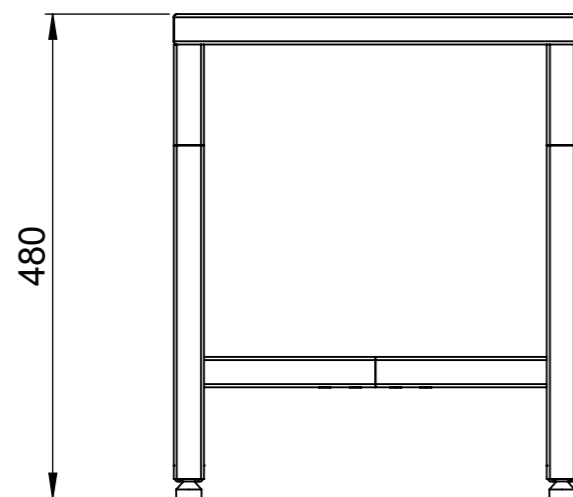

U80-86 Join Stool 480

Including adjustable feet, 5 connectors,
and 20 countersunk M6-screws.
Comes disassembled. **Weight 11,5 kg**

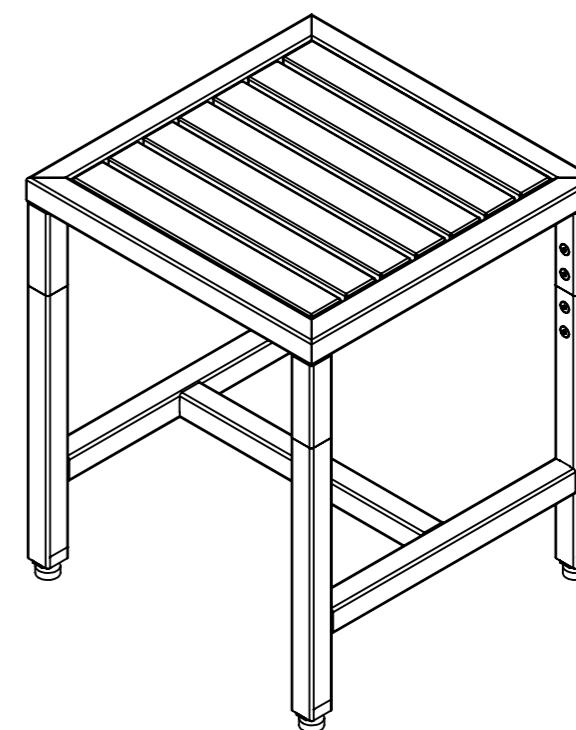

Join Terrace furniture

Join Stool perforated 480

Ritad av Odin Sollie
Uppdaterad 2023-10-31

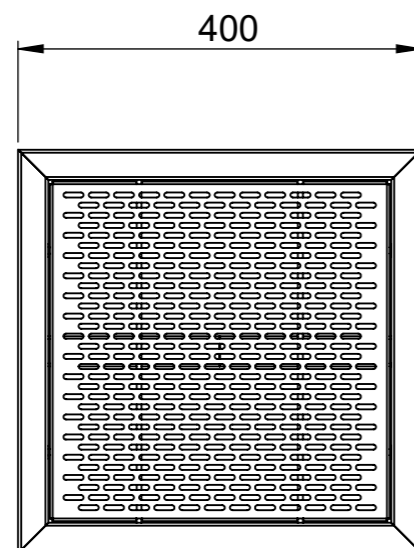
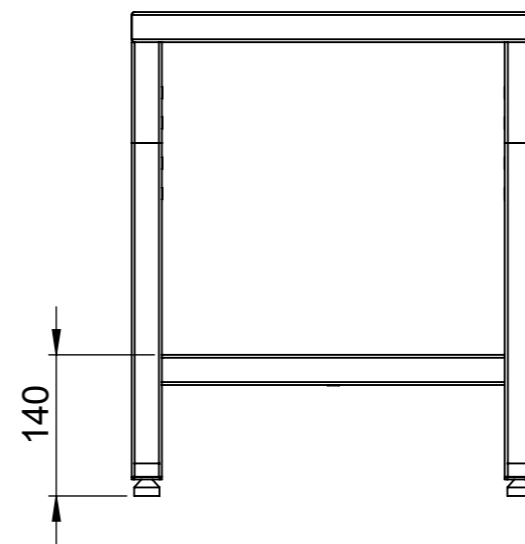
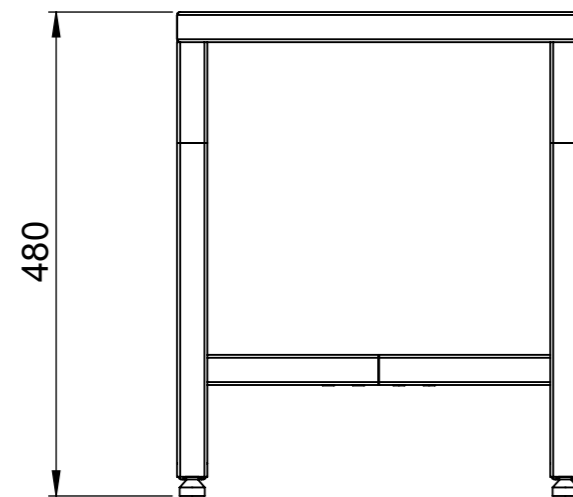

U80-86PP Join Stool perforated 480

Including adjustable feet, 5 connectors,
and 20 countersunk M6-screws.
Comes disassembled. **Weight 11 kg**

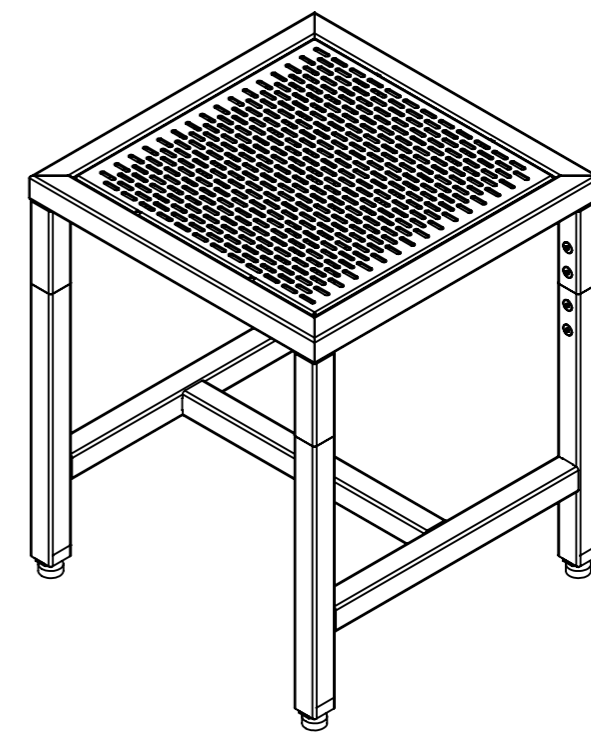

Join Terrace furniture

Join Tabletop for planter

Ritad av Odin Sollie
Uppdaterad 2023-10-31

U80-87 Join Tabletop for planter

Comes assembled. **Weight 11 kg**

