

nola®



Visättra Furniture Group

Design Peter Ekroth

No outdoor space would be complete without a smart place to sit. With their robust wooden slats and resilient metal frames, the benches and armchairs in the Visättra group bring attractive seating to outdoor environments. Visättra is a popular choice for public areas where high volumes of human traffic necessitate hardwearing outdoor furniture. The long version of the backed bench provides extra seating in busy places. Optional armrests add extra support and accessibility.

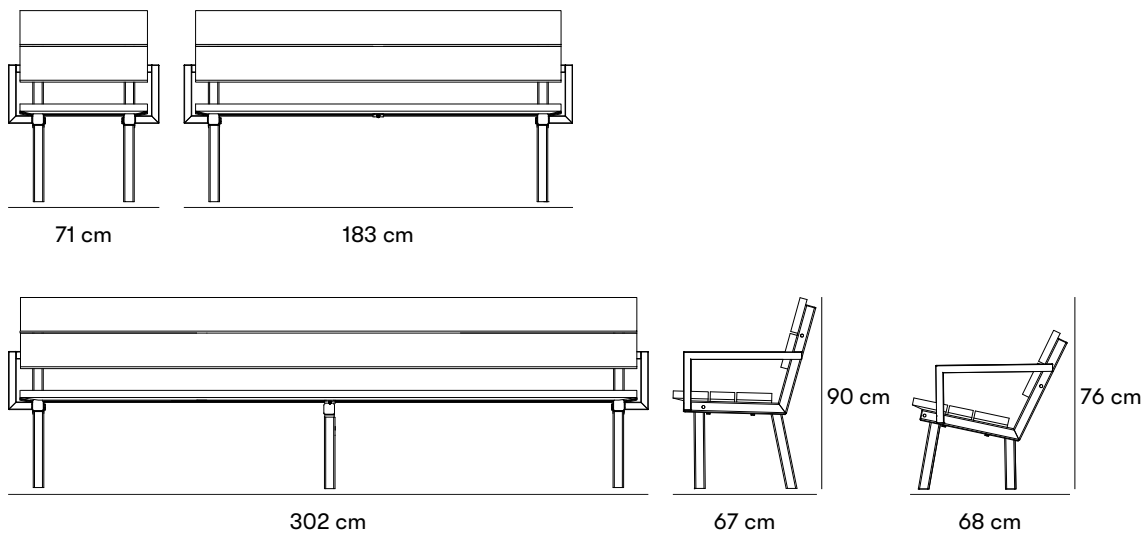

Dimensions and weight

Sitting height: 43,5 cm (lutning går att anpassa samt höjd se monteringsanvisningen)

Sofa: 180 cm Long sofa: 290 cm Armchair: 60 cm Depth: 73 cm Height: 75 cm
 Seat height: 45 cm Weight: Sofa 180 cm 51.5 kg Long sofa 78.5 kg Armchair 30.5 kg

Product numbers and combinations

U17-70A Visättra backed bench

U17-71A Visättra armchair

U17-72A Visättra long backed bench

U17-70D Visättra extra armrest

B11-06 Startup cost for powder coating steel in a color other than standard. Choose a RAL colour.

B11-07 Starting cost for another color of wood. Choose brown or grey for Linax or an NCS color for painted wood. If you want the same color on both steel and wood, choose the RAL color for both.

Append to product number

WOOD AND FINISH

EK for oiled oak.

C for any color other than standard for painting wood, initial cost is added.

Choose an NCS color. If you want the same color on both steel and wood, choose the RAL color for both.

METAL SURFACE FINISH

C for any color other than standard, starting cost is added. Choose a RAL colour.

INSTALLATION TYPE

M for in-ground.

Standard colours

■ RAL 5008

Materials and surface treatments

Pine

Nola's pine is of high quality and comes from sustainable forestry. Pine is an environmentally friendly, domestically produced material. Damaged or untreated pine is quite easily attacked by decomposition processes; therefore, it is particularly important to repair damaged surfaces.

Oak

Oak is a heavy, hard and medium tough wood. Moderately dimensionally stable in case of moisture changes. Oak wood blackens if it is exposed to moisture or wetness for a long time. However, it does not affect the other properties of the wood. Thanks to its hardness and toughness, the oak wood is suitable for furniture and other use in exposed environments.

Water-based glaze

Varnishing of wood is done with a water-based varnish. A water-based paint that is kinder to the environment. Under normal use, the paint has a good wear resistance and long durability.

Wood oil

Wood oil provides good protection against the stresses of the outdoor climate and at the same time highlights the wood's natural appearance and properties.

Steel

Nola uses high-quality steel with good strength in our products. Steel rusts if left untreated and must therefore be surface treated.

Electrogalvanized

Electrogalvanizing (also known as zinc plating) provides corrosion protection through the sacrifice of zinc ions. It is created via a zinc coating on the steel using an electric current.

Powder coating

Powder coating is a coating that is applied as a free-flowing, dry powder. Unlike conventional liquid paint, powder coating is usually applied electrostatically and then cured under heat or with ultraviolet light. The result is an even, hard-wearing coloured surface with the desired gloss level.

Assembly and placement

In-ground

Cast in ground.

Delivered in parts: stand, seat and back.

The stand is cast at an angle, for the desired inclination.

Maintenance

Water-based glazed pine

Products in varnished pine must be maintained regularly with alkyd paint. Maintenance intervals approximately 1 time per year. Damage and cracks should be repaired immediately. Touch-up paints in spray packaging are available in standard colors to order.

Oiled oak

Oiled oak should be oiled twice a year for best protection. Good maintenance can never completely prevent stains from occurring, but oak that is not maintained will turn blacker and turn gray faster, but it still has a very long life. When re-oiling products, a finely boiled oil that penetrates the wood should be chosen over a film-forming oil.

Powdercoated steel

Products that are powder-coated can be touch-up painted with alkyd paint.

[Read more in our general maintenance advice at nola.se/en/care-and-maintenance](https://nola.se/en/care-and-maintenance)

Versions

The furniture group consists of a sofa 180 cm, a long sofa 290 cm and an armchair.

Available with or without armrests.

Standard color:

Steel dark blue RAL 5008 with wood dark blue NCS S 8010 R90B

For any color, a start-up cost will be added.

Character

Generous furniture group, adaptable as needed in the form of slope and armrests.

Designers

Peter Ekroth

Landskapsarkitekt
och konstnär.



