



## Viaduct Bench

**Design Anki Gneib**

The granite bench Viaduct draws historical references from the garden where it was exhibited during the Stockholm Creative Edition. Viaduct's form was inspired by Roman aqueducts and viaducts, and the bench has a strong architectural presence.

In early 2023 we launched a development of the bench – a wooden version for indoor use made in cross-laminated timber. All the wood used in this particular production is a residual product from making CLT panels (such as cutting out windows and doors) for the building industry.

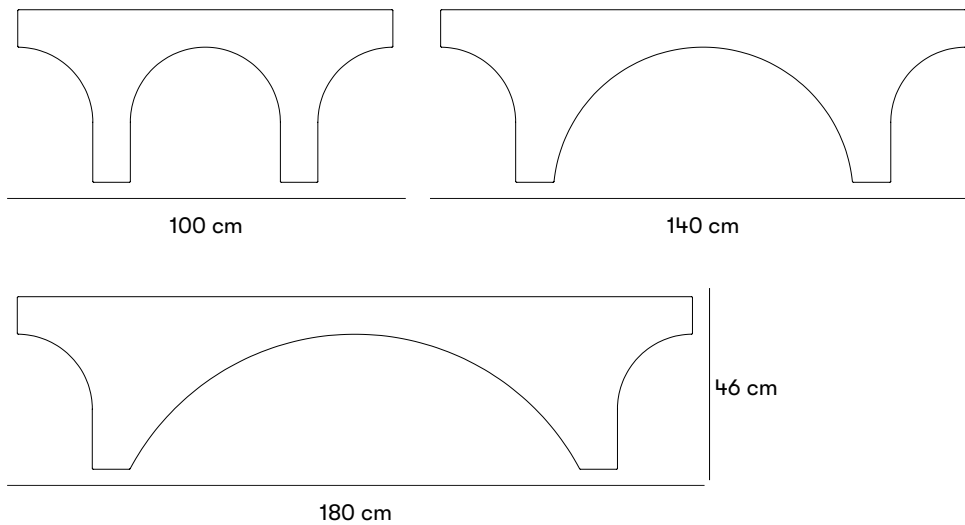

**Dimensions and weight**

Length: 100 cm, 140 cm och 180 cm  
 Width: 42 cm  
 Height: 46 cm

Bench length 100 cm. Weight in granite: 220 kg. Weight in CLT wood: 48 kg.

Bench length 140 cm. Weight in granite: 320 kg. Weight in CLT wood: 69 kg.

Bench length 180 cm. Weight in granite: 420 kg. Weight in CLT wood: 91 kg.

**Product numbers and combinations**

U30-30/100 Viaduct Bench 100 cm  
 U30-30/140 Viaduct Seat bench 140 cm  
 U30-30/180 Viaduct Seat bench 180 cm

**Append to product number**

**VARIANTS**

G for grey Bohus Granite

KL for recycled Cross Laminated Timber (indoor use only)

**Standard colours**

- Grey Bohus Granite
- CLT - Cross Laminated Timber

**Materials and surface treatments**

Gray Bohus Granite.  
 Cross-Laminated Wood.

**Assembly and placement**

**Freestanding**

Freestanding product that is placed directly on the ground.

Levereras monterad.

Due to its high weight, Viaduct Bem is recommended in all cases and contexts to be placed on a solid surface that does not risk sinking over time. ie hard surfaces such as asphalt, tiles, cast concrete or hard packed gravel surface. Viaduct Bänk does not have lifting loops. When lifting the bench, which should always be done with machinery, lifting straps that can be looped under the bench are recommended. See installation instructions.

#### Maintenance

Clean as necessary. Use granite cleaners and follow the instructions.  
[Read more in our general maintenance advice at nola.se/en/care-and-maintenance](https://nola.se/en/care-and-maintenance)

#### Versions

Tre längder kombinerbara med varandra.

#### Character

Heavy stable and sculptural bench that can be placed individually or in a longer row.

#### Designers

---

##### Anki Gneib

Anki Gneib has an education in Interior Architecture and Furniture Design at the University College of Art, Crafts and Design in Stockholm. In her studio, she works creatively with a wide range of projects such as residential architecture, interior design for commercial spaces with a focus on facility branding as well as furniture, lighting and product design. Her work is characterized by experimental and playful expressions through both process and results.





