

nola®



Paxa 2 and 3 Bench and Sofa

Design Blenda Design

The Paxa outdoor furniture group is considered a masterpiece of materials and form. The table stands on two asymmetrical legs, each balancing the surface weight between them. The benches are designed in sections that combine seamlessly to form extended lengths. Available in smooth concrete or lightweight steel, the choice of legs can make the products appear more robust, or create a streamlined style. The tabletop and seating surfaces are crafted in oiled mahogany, oiled oak or painted pine.

CERTIFICATION

Produkt listad i
Svanens Husportal  BYGGGARU
BEDÖMNINGEN

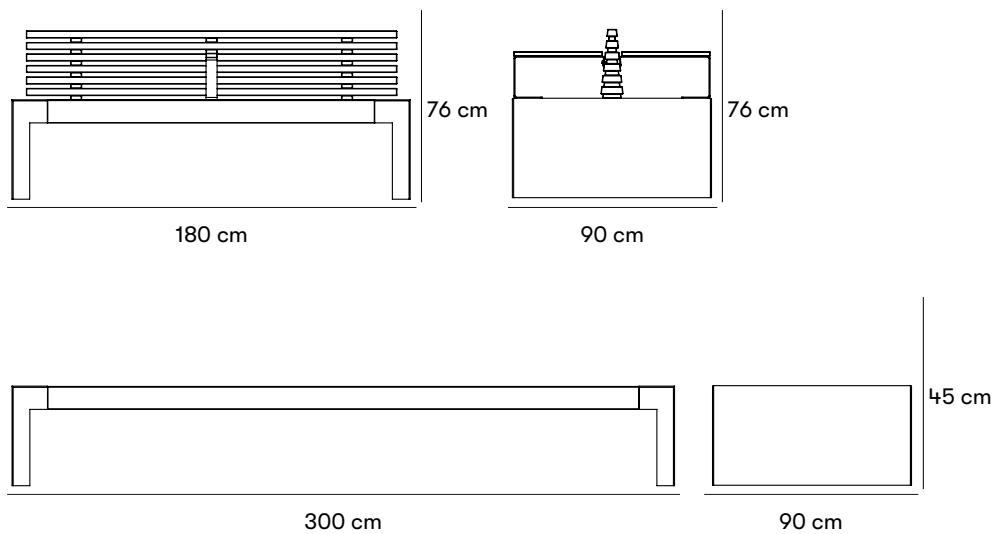

Dimensions and weight

BENCH 1 (U20-60) Length: 180 cm Height: 45 cm Width: 50 cm Weight: 150 kg
 Seat length: 148 cm Seat thickness: 11.5 cm Seat width: 50 cm Seat weight: 34 kg

BENCH 2 (U20-64) Length: 180 cm Height: 45 cm Width: 90 cm Weight: 233 kg
 Seat length: 148 cm Seat thickness: 11.5 cm Seat width: 90 cm Seat weight: 53 kg

BENCH 3 (U20-68) Length: 300 cm Height: 45 cm Width: 90 cm Weight: 361 kg
 Seat length: 268 cm Seat thickness: 11.5 cm Seat width: 90 cm Seat weight: 82 kg

Product numbers and combinations

U20-64 Paxa 2 complete Bench, length 180 cm, width 90 cm

U20-64R Paxa 2 complete Park bench, length 180 cm, width 90 cm, with pyramid-shaped central backrest

U20-68 Paxa 3 complete Bench, length 300 cm, width 90 cm

U20-64/ARM Armrest for Paxa 2 version with backrest

Append to product number

WOOD AND FINISH

EK for oiled oak.

MH for oiled mahogany.

G for tabletop in glazed pine. NCS S 6000-N (grey).

C for any NCS color other than standard, starting cost is added.

VARIANTS



A for frame coloured in antracite

No letter after the article number for light grey natural concrete.

INSTALLATION TYPE

M for installation in pre-cast foundations.

Standard colours

-  NCS S 6000-N (grå)
-  Ljust grå betong ofärgad
-  Infärgad antracitgrå betong

 Oiled oak

 Oiled mahogany

Materials and surface treatments

Pine

Nola's pine is of high quality and comes from sustainable forestry. Pine is an environmentally friendly, domestically produced material. Damaged or untreated pine is quite easily attacked by decomposition processes; therefore, it is particularly important to repair damaged surfaces.

Mahogany - FSC-certified

FSC-marked mahogany is a wood with good durability in the outdoor environment. In addition, it retains its color tone better than, for example, oak and teak. Mahogany lives and moves, sometimes more than teak.

Oak

Oak is a heavy, hard and medium tough wood. Moderately dimensionally stable in case of moisture changes. Oak wood blackens if it is exposed to moisture or wetness for a long time. However, it does not affect the other properties of the wood. Thanks to its hardness and toughness, the oak wood is suitable for furniture and other use in exposed environments.

Wood oil

Wood oil provides good protection against the stresses of the outdoor climate and at the same time highlights the wood's natural appearance and properties.

Water-based glaze

Varnishing of wood is done with a water-based varnish. A water-based paint that is kinder to the environment. Under normal use, the paint has a good wear resistance and long durability.

Concrete

Concrete is cement mixed with crushed stone or aggregate. The material is very strong in compression but fragile in tension. To compensate for this concrete can be reinforced, often with steel.

Coloured concrete

Colored concrete is concrete in a color other than standard grey. Pigment is added to the dry mixture, which means that the concrete becomes coloured throughout. Each color has its own recipe.

Assembly and placement

Installation in pre-cast foundations

Posts for installation in pre-cast foundations.

Delivered in parts for assembly on site.

Maintenance

Oiled oak

Oiled oak should be oiled twice a year for best protection. Good maintenance can never completely prevent stains from occurring, but oak that is not maintained will turn blacker and turn gray faster, but it still has a very long life. When re-oiling products, a finely boiled oil that penetrates the wood should be chosen over a film-forming oil.

Oiled mahogany

Oiled mahogany should be oiled two times a year.

Water-based glazed pine

Products in varnished pine must be maintained regularly with alkyd paint. Maintenance intervals approximately 1 time per year. Damage and cracks should be repaired immediately. Touch-up paints in spray packaging are available in standard colors to order.

Concrete

Both normal concrete and fibre-reinforced concrete are sensitive to hard edge impacts. A concrete product that has been damaged can be repaired with polyester filler, such as the product "Plastic Padding".

Coloured concrete

Products made of coloured concrete are washed with a pressure sprayer at low pressure. Damaged products can be repaired with a repair kit that is available to order.

[Read more in our general maintenance advice at nola.se/en/care-and-maintenance](https://nola.se/en/care-and-maintenance)

Character

Lättplacerad Sofa. Kan kopplas ihop i flera sektioner.

Designers

Blenda Design

Blenda is a designstudio based in Gothenburg, committed to designing furniture for public spaces. With design that works towards both interiors and urban exteriors, they have participated in many projects in the recent years. The products can be found across Sweden, for example in Stavanger Cultural Center, Museum of Modern Art in Stockholm, Arlanda Airport and Gothenburg City library. The studio is run by landscape architect Katarina Gunnarsson and Ingemar Holmlid.



