

nola®



Join Table

Design

Join is a versatile furniture series suitable for outdoor spaces like terraces and courtyards. The series includes benches, stools, tables, side tables, and planters. The lightweight construction of the furniture allows for easy mobility and the creation of various configurations. The higher bench with a seating height of 65 centimeters promotes active sitting.

The pieces can be easily arranged according to needs and space, with the green planters serving as islands or dividers. The furniture is made of steel with wooden details for a softer feel. The patterned perforations provide a decorative break and a consistent design element throughout the series. All components have adjustable feet for stable placement on uneven surfaces.

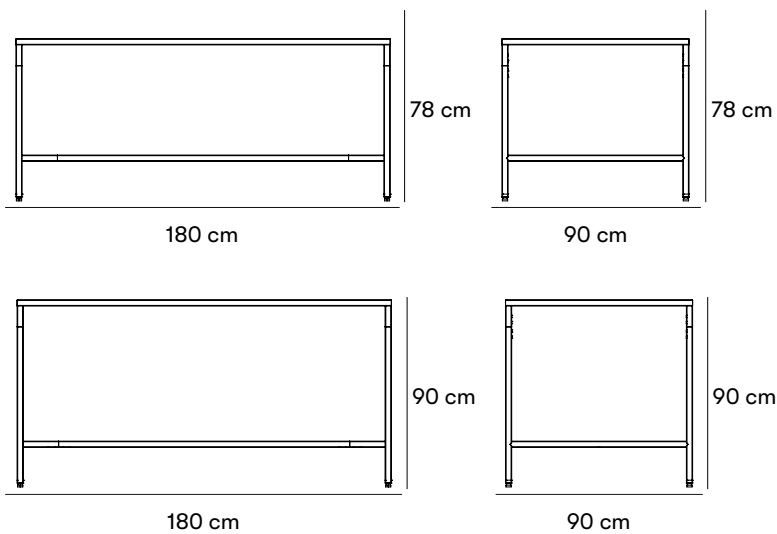

Dimensions and weight

U80-81 Join Table. H: 90 cm L: 180 cm W: 90 cm. Weight: 44 kg.

U80-84 Join Table. H: 78 cm L: 180 cm W: 90 cm. Weight: 43 kg.

Product numbers and combinations

U80-81 Join Table 90 cm

U80-84 Join Table 78 cm

U80-81BESLAG Attachment hardware, 1 pc.

Append to product number

WOOD AND FINISH

EK for oiled oak.

METAL SURFACE FINISH

RAL 9005

C for any color other than standard, starting cost is added.

INSTALLATION TYPE

N for surface mount.

Standard colours

■ RAL 9005

■ Oiled oak

Materials and surface treatments

Steel

Nola uses high-quality steel with good strength in our products. Steel rusts if left untreated and must therefore be surface treated.

Electrogalvanized

Electrogalvanizing (also known as zinc plating) provides corrosion protection through the sacrifice of zinc ions. It is created via a zinc coating on the steel using an electric current.

Powder coating

Powder coating is a coating that is applied as a free-flowing, dry powder. Unlike conventional liquid paint, powder coating is usually applied electrostatically and then cured under heat or with ultraviolet light. The result is an even, hard-wearing coloured surface with the desired gloss level.

Oak

Oak is a heavy, hard and medium tough wood. Moderately dimensionally stable in case of moisture changes. Oak wood blackens if it is exposed to moisture or wetness for a long time. However, it does not affect the other properties of the wood. Thanks to its hardness and toughness, the oak wood is suitable for furniture and other use in exposed environments.

Wood oil

Wood oil provides good protection against the stresses of the outdoor climate and at the same time highlights the wood's natural appearance and properties.

Assembly and placement

Freestanding

Freestanding product that is placed directly on the ground.

Surface mount

Can be bolted above ground, to the floor or to a cast-in-place foundation. Bolts not included.

Products in the Join Furniture series are delivered disassembled, check the assembly instructions for information on each product's individual assembly.

Maintenance

Powdercoated steel

Products that are powder-coated can be touch-up painted with alkyd paint.

Oiled oak

Oiled oak should be oiled twice a year for best protection. Good maintenance can never completely prevent stains from occurring, but oak that is not maintained will turn blacker and turn gray faster, but it still has a very long life. When re-oiling products, a finely boiled oil that penetrates the wood should be chosen over a film-forming oil.

[Read more in our general maintenance advice at nola.se/en/care-and-maintenance](https://nola.se/en/care-and-maintenance)