

nola®



High Round Bench Seating

Design Mats Aldén

The High Round Bench seating design adds something fundamental to the Low/High series. Although Round Bench is conceived as a seat, it can provide a round platform with a range of potential uses. Round Bench can be installed in its original whole version or as an integrated seating/planter design. As a result, Round Bench provides a flexible seating system for urban squares, city parks, roof terraces and courtyards. High Round Bench can be supplemented with a planter.

CERTIFICATION

Produkt listad i
Svanens Husportal    **SundaHus**

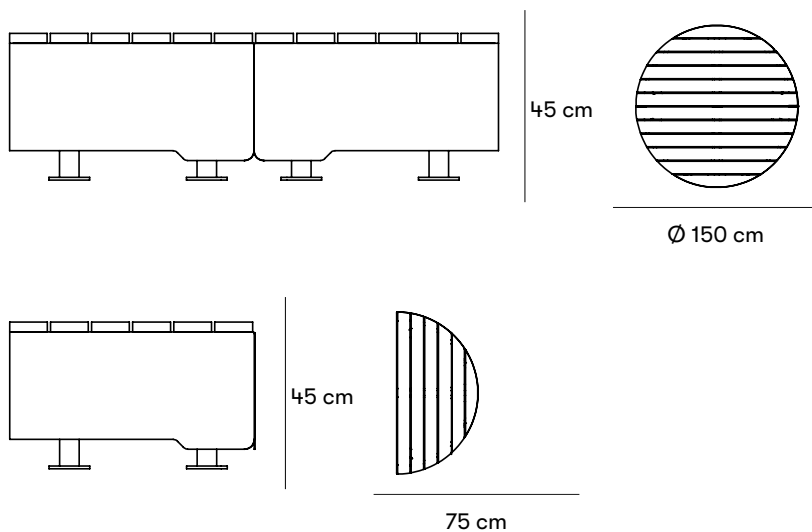

Dimensions and weight

Width: 150 cm
 Sitting height: 45 cm
 Sitting depth: 75 cm
 Ø: 150 cm

Product numbers and combinations

U11-58RH High Round Bench, half circle
 U11-58RH/2 High Round Bench, 2 half circles
 U11-58RP High Round Planter, half circle
 U11-58RH/2P High Round Bench and Planter, 2 half circles
 B11-05 Additional fee for choice of non-standard wood
 B11-06 Additional fee for choice of non-standard colour

Append to product number

WOOD AND FINISH

EK for oiled oak.
 LIN for linax impregnated pine.

METAL SURFACE FINISH

GR for gray Gris 2150 Sablé.
 V for white RAL 9010.
 C for any color of steel, at an additional cost. Choose a RAL colour.

INSTALLATION TYPE

N for surface mount.

Standard colours

 RAL 6015
 RAL 3005
 RAL 9005
 RAL 5015

 Oiled oak

 Linax impregnated pine

Materials and surface treatments

Pine

Nola's pine is of high quality and comes from sustainable forestry. Pine is an environmentally friendly, domestically produced material. Damaged or untreated pine is quite easily attacked by decomposition processes; therefore, it is particularly important to repair damaged surfaces.

Oak

Oak is a heavy, hard and medium tough wood. Moderately dimensionally stable in case of moisture changes. Oak wood blackens if it is exposed to moisture or wetness for a long time. However, it does not affect the other properties of the wood. Thanks to its hardness and toughness, the oak wood is suitable for furniture and other use in exposed environments.

Steel

Nola uses high-quality steel with good strength in our products. Steel rusts if left untreated and must therefore be surface treated.

Wood oil

Wood oil provides good protection against the stresses of the outdoor climate and at the same time highlights the wood's natural appearance and properties.

Powder coating

Powder coating is a coating that is applied as a free-flowing, dry powder. Unlike conventional liquid paint, powder coating is usually applied electrostatically and then cured under heat or with ultraviolet light. The result is an even, hard-wearing coloured surface with the desired gloss level.

Electrogalvanized

Electrogalvanizing (also known as zinc plating) provides corrosion protection through the sacrifice of zinc ions. It is created via a zinc coating on the steel using an electric current.

Linax

Linax is a linseed oil-based impregnation that provides extra long durability in outdoor environments and corresponds to impregnation class AB. The impregnated wood turns gray over time, which means that it should be re-oiled if necessary. Use a linseed-based oil for impregnated materials.

After traditional impregnation according to NTR AB, the wood is boiled in a hot linseed oil with or without color pigments under vacuum. The oil is penetrated into the surface on all six sides, which reduces moisture absorption in the wood and gives a dimensionally stable product over time. The result is a dried product with good resistance to rot that also has long maintenance intervals. Linax-impregnated furniture is intended for outdoor environments only.

Assembly and placement

Freestanding

Freestanding product that is placed directly on the ground.

Surface mount

Can be bolted above ground, to the floor or to a cast-in-place foundation. Bolts not included.

U11-58ERH

High Round Bench, halvcirkel

Sits + 4 st M5x5 skruvar och

frontplåt + 8 st M8 muttrar och brickor.

Sits och frontplåt monteras på möbeln

efter fastsättning i mark. Bult mot mark ingår ej.

U11-58ERH/2

High Round bench dubbel, cirkel.

Inklusive 2 st sitsar + 8 st M5x5 skruvar.

Sitsarna monteras på möbeln av kunden

efter ihopmontering och fastsättning i mark.

Bult mot mark ingår ej.

Fastsättning

Möbelhalvorna i serien har 3 st hålförsedda fotplattor för montering med 3 st M10-skruvar per fotplatta.

Fotplattornas hålbild är alla likadana.

Montering på träunderlag

Med möbeln satt på sin plats, förborra genom fotplattornas hål och montera med fransk träskruv

Montering på smågatsten eller gatuplattor

Udergjut plattorna med betong enligt benens CC-mått på sid. 2 och 3. Det får ej finnas sättsand mellan plattorna och betongen.

Sätt möbeln på plats och markera hålens position. Borra plattan för expander eller kemankare.

Montering mot betong eller stenblock etc.

Montera med kemankare eller expander enligt ovan. Montage med expander ger en demonterbar fastsättning.

Maintenance

Oiled oak

Oiled oak should be oiled twice a year for best protection. Good maintenance can never completely prevent stains from occurring, but oak that is not maintained will turn blacker and turn gray faster, but it still has a very long life. When re-oiling products, a finely boiled oil that penetrates the wood should be chosen over a film-forming oil.

Linax impregnated pine

Outdoor furniture requires oiling every 5 years and panel products and roofs require oiling every 12 years. Maintenance should be done with linseed oil varnish. It is important that the wood is clean and dry (max. 20% moisture content) before it is finished with oil. When washing, do not use high-pressure cleaners. Washing should be done with lukewarm water and then rinsed off with a water hose at normal pressure. Strong grease-dissolving agents should not be used, but washing should be done with a mild household detergent. Detergents containing bleach should also not be used.

The oil can be applied with a roller or brush. Too much oil can cause growth on the wood and give a sticky surface. Attacks by growth can also occur if the wood has not been sufficiently dry or cleaned before the oil is applied. Growth does not damage the wood and is relatively easy to remove, but has a tendency to return.

Powdercoated steel

Products that are powder-coated can be touch-up painted with alkyd paint.

[Read more in our general maintenance advice at nola.se/en/care-and-maintenance](https://nola.se/en/care-and-maintenance)

Character

Stor och robust sittbänk med rund form. Beställs antingen som hel eller halvcirkel.

Designers

Mats Aldén

Interior and furniture designer, crafter and tutor living in Stockholm. Educated at Aarhus School of Architecture, Denmark. Has his own design studio and workshop in Stockholm since 1995. Has worked as a professor and artistic leader at Steneby HDK, as a lecturer at Konstfack University College of Arts, Crafts & Design and as a guest teacher at Beckmans Design College.

