

nola®



Arena Furniture System

Design Mattias Stenberg

Arena meets the demand for a modular furniture system that's flexible, easy to assemble, quick to take apart and easy to store. The system consists of individual seating units, side tables and planters, all designed in a uniquely streamlined style. Each seat is crafted in smooth concrete and underpinned by a slender metal base. Arena's versatility enables the system to form a wide range of constellations.

CERTIFICATION

Produkt listad i
Svanens Husportal  

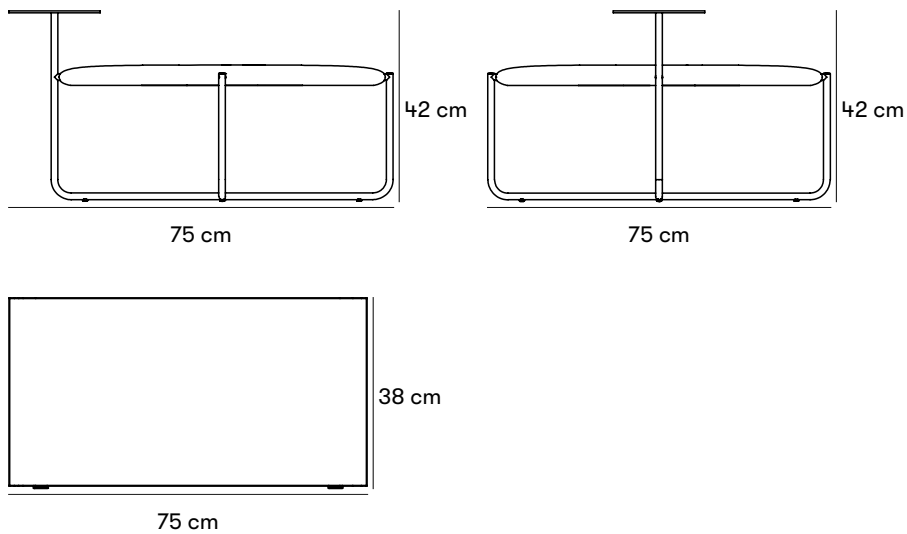

Dimensions and weight

Length: 75 cm

Width: 75 cm

Height: Stålsits, bord & planteringskärl 38 cm. Påhångsbord 66 cm

Sitting height: Betongsits 42 cm Stålsits/bord 38 cm

Ø: 30 cm (påhångsbord)

Seat: Width: 75 cm Hight: 42 cm. Depth: 75 cm.

Bord: Width: 75 cm Hight: 38 cm. Depth: 75 cm.

Planter: Width: 75 cm. Hight: 38 cm. Depth: 75 cm.

Table: Ø: 30 cm. Hight: 66 cm.

Product numbers and combinations

U31-01B Arena module with concrete seat

U31-01S Arena module with steel seat

U31-02/PLANT Arena planter

U31-02 Arena planter pot

U31-03/BORD Arena small round table

U31-04-12 Arena attachment hardware no 2. 1 piece

U31-04-13 Arena attachment hardware no 3. 1 piece

U31-04-14 Arena attachment hardware no 4. 1 piece

B11-06 Startup cost for powder coating steel in a color other than standard

Append to product number

METAL SURFACE FINISH

C for any color other than standard, starting cost is added.

Standard colours

 RAL 3009

 Ljust grå betong ofärgad

Materials and surface treatments

Seat in "soft concrete" (fiber concrete) integrated with the metal base.

Steel

Nola uses high-quality steel with good strength in our products. Steel rusts if left untreated and must therefore be surface treated.

Powder coating

Powder coating is a coating that is applied as a free-flowing, dry powder. Unlike conventional liquid paint, powder coating is usually applied electrostatically and then cured under heat or with ultraviolet light. The result is an even, hard-wearing coloured surface with the desired gloss level.

Electrogalvanized

Electrogalvanizing (also known as zinc plating) provides corrosion protection through the sacrifice of zinc ions. It is created via a zinc coating on the steel using an electric current.

Fiberbetong

Fibre-reinforced concrete is a concrete mix with glass fiber. The material has increased strength and elasticity.

Coloured concrete

Colored concrete is concrete in a color other than standard grey. Pigment is added to the dry mixture, which means that the concrete becomes coloured throughout. Each color has its own recipe.

Assembly and placement

Freestanding

Freestanding product that is placed directly on the ground.

Seats and tables are mounted on the same substructure and easily connected with integrated coupling brackets.

The seats are joined to each other via metal fasteners integrated into the bases underneath, with space for the table and planter to attach at the sides.

Maintenance

Powdercoated steel

Products that are powder-coated can be touch-up painted with alkyd paint.

GRC

Both normal concrete and fibre-reinforced concrete are sensitive to hard edge impacts. A concrete product that has been damaged can be repaired with polyester filler, such as the product "Plastic Padding".

Coloured concrete

Products made of coloured concrete are washed with a pressure sprayer at low pressure. Damaged products can be repaired with a repair kit that is available to order.

[Read more in our general maintenance advice at nola.se/en/care-and-maintenance](https://nola.se/en/care-and-maintenance)

Versions

Modular furniture system consisting of seats, table and a planting box.

Character

The Arena modular seating system is a versatile design that's simple to assemble, quick to take apart, and easy to store.

Designers

Mattias Stenberg

Designer Mattias Stenberg runs his own designstudio in Stockholm. Stenberg works within a variety of fields including interior architecture, furniture design and light design. Since the start of the studio in 2010, Stenberg has received several awards and mentions for his designs, including German Design Award, Good Design Award and Nordic Designer of the Year.

