

## “VENERE” Planter

**Sheet code:** FIPP002

**Drawing code:** AF01100302

**Revision:** 22/01/2019

**Designer:**  
Bellitalia Design Department

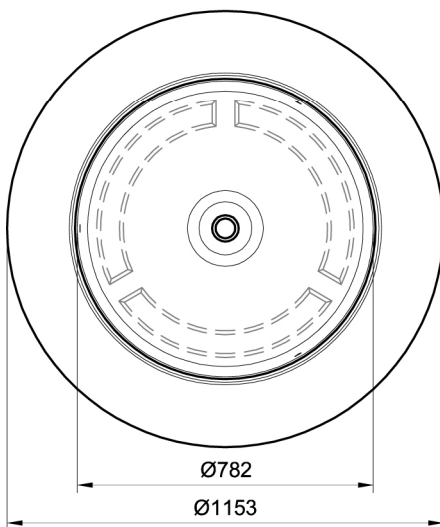
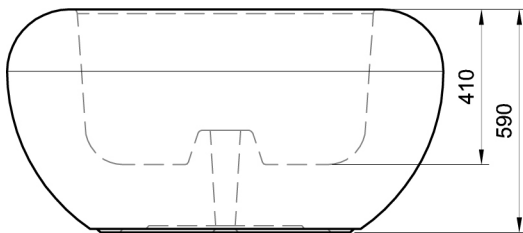

**Product:** Monolithic planter model “VENERE”, fitted with a combined **water reserve system** and **overflow discharge**, to guarantee the soil the proper humidity level, avoiding the dispersion of internal water.

**Dimensions:** external diameter: 1153 mm;  
maximum height: 590 mm;  
total weight: 800 kg;  
capacity: 178 litres.

**Material:** The planter can be manufactured using reconstituted natural marble stones or white granite conglomerate.

**Reinforcing:** The planter is reinforced, with internal bushes for lifting.

**Finishing:** The planter's surface can be polished, to give the product a shiny effect, or bush-hammered, for a rough appearance. The surface is then covered with a transparent anti-decay coating, or, upon request, with anti-graffiti products. All edges are rounded or made blunt.

**Handling:** Use appropriate equipment when handling, screwing the eyebolts to the bushes.

**Installation:** Simply place the planter on the flooring and remove the eyebolts used for lifting.